

USER'S GUIDE

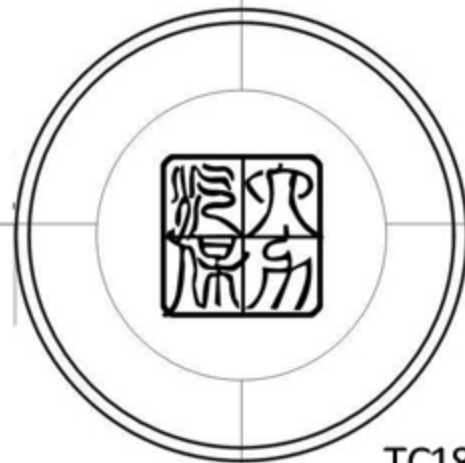

TYRE CHANGER



TC1820

OUTLINE

1 GENERAL PROVISION

- This instruction is one integrated part of the products. You must carefully read the warnings and instructions described in this manual before use the product. All these warnings and instructions will provide you with the important information regarding safe usage and maintenance.
- Properly keep this manual for the reference in the future.
- Careful reading this instruction manual can lead the operator to use the machine correctly and in this case the dealer will provide long-term and effective after-sales services. The producer and dealers will not be responsible for the problems caused by any incorrect operation.

- **Danger**

The process can directly cause the serious damage or death.

- **Warning**

The unsafely process can cause the serious damage or death.

- **Note**

The unsafely process can cause the serious damage or death.

- Before connect the power supply and air supply, you should carefully read he manual. Keep the operation notes and warning notes on the manual and machine. The related information data and the documents and data in the sales process should be carefully kept. Different machine serial numbers will be equipped with different instruction manual. The operators should pay attention to the effectiveness if the manual.



Danger

You must use the machine in accordance with the requirements specified in the manual. The producer and dealers will not be responsible for the problems caused by any incorrect operation.



Warning

The machine must be operated by the professional personnel. The operator must understand the manual and have taken the professional training. If the nonprofessional personnel operate the machine, it will cause the dangerous of personal injuries and also lead to the damage to the tire and rim.



Notes

The pictures in the manual all comes from the original design structure of the machine. The structure showed in the pictures may be different from the actual structure of the machine.

The machine is made for the purpose to give guidance to the personnel with some basis of mechanical and electrical skills. Therefore, the basic processes such as how to fix the bolts may be omitted. Do not try to letting the personnel without experience operate the machine. If you have any requirement related to this, please ask the dealer to provide the help.

2. TECHNICAL PARAMETER

● OVERALL DIMENSION

- Length-----A = 1130mm
- Max length----- A = 1620mm
- Breadth-----B = 1050mm
- Max. breadth during operation process----- B1 = 1550 mm
- Min. Height----- H = 1710 mm
- The wheel applicable: standard wheel, reverse wheel, wheel without center hole, run flat wheel.

● Range of the wheel

- Rim diameter ----- 9”~26”
- Max. tire diameter-----960mm
- Max. tire width----- 13”

● Turntable type

- Clamped by ----- clamping jaw
- Fixed by----- clamping jaw
- Clamp style----- pneumatic
- Driven by-----motor
- Torque-----1100 Nm
- Number of revolution-----7 /14rpm

● Bead breaking system

- Bead breaking tool----- blade
- Fix style----- manual
- Plug in style-----pneumatic
- Max. work dimension-----340mm
- Press disk pressure-----2500KG

● Power supply

- Single phase -----220V/110V-1.1kW 50Hz/60 Hz
- Three phase-----380V/0.7-0.9kw/1400-2800r/min
-

- Air supply pressure-----8-10 bar

● Noise

The noise emission at the workstation -----< 70 dB

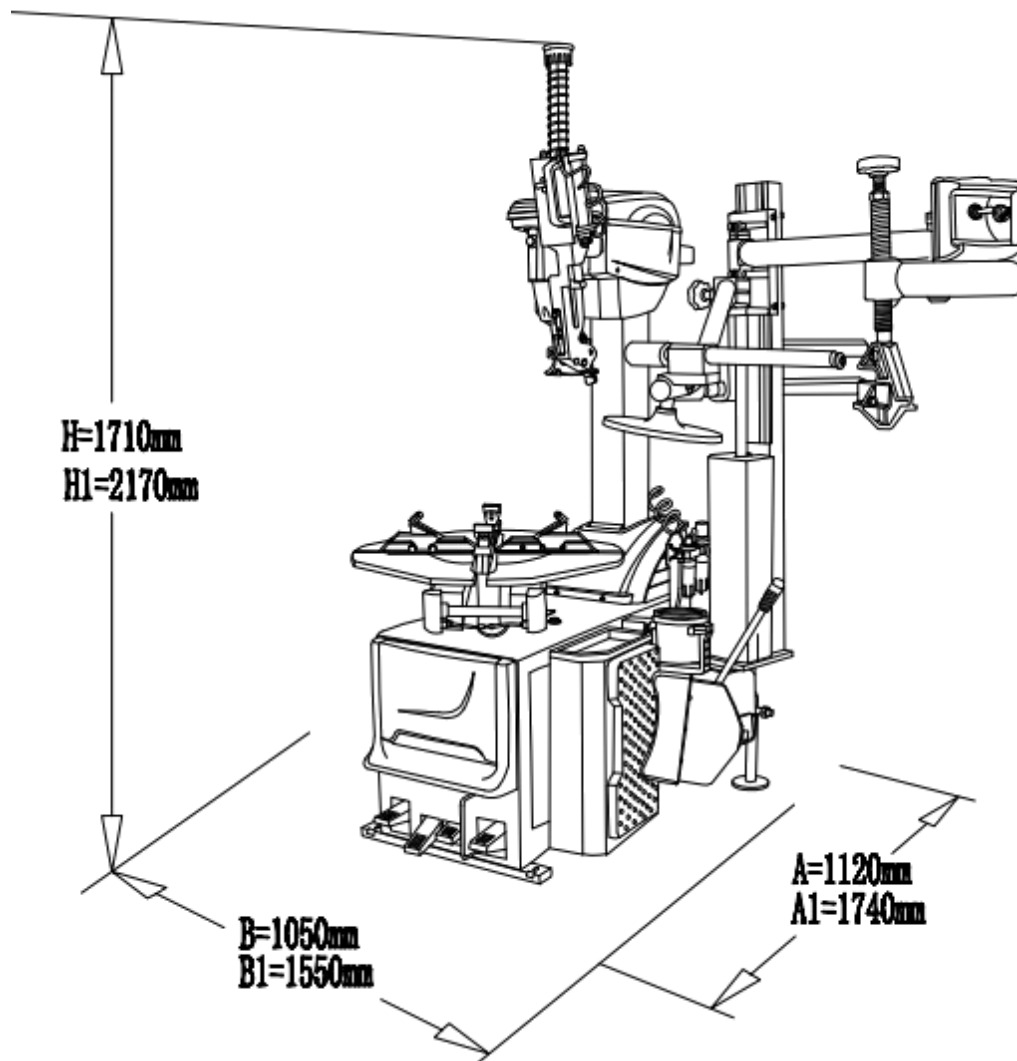

3. Scopes

This machine is the tire changer driven by air and electrical. It can handle car tire, the weight and dimension as per the chapter of technical parameter.

- **The tire applicable:**

- Tire standard and common
- Reverse tire
- Tire without center hole,
- Run flat tire



Warning: Each type of tire has its special operation method

- Note: When demount/ mount the tire of the old car, exceeding 30years/ modified car tires/ tire with the rim modified, it may cause the accident.

4. Machine diagram



Warning

Understand all the information related to the machine

Understand how to prevent the appearance of the accident

Understand how to use the tire changer

Understand all the function

Understand the entire control key

Understand each operation of the control part

All these understanding can prevent the safety accident and guarantee the correct running of the tire changer. The installation of the machine must be correct and operate correctly and also execute the maintenance periodically.

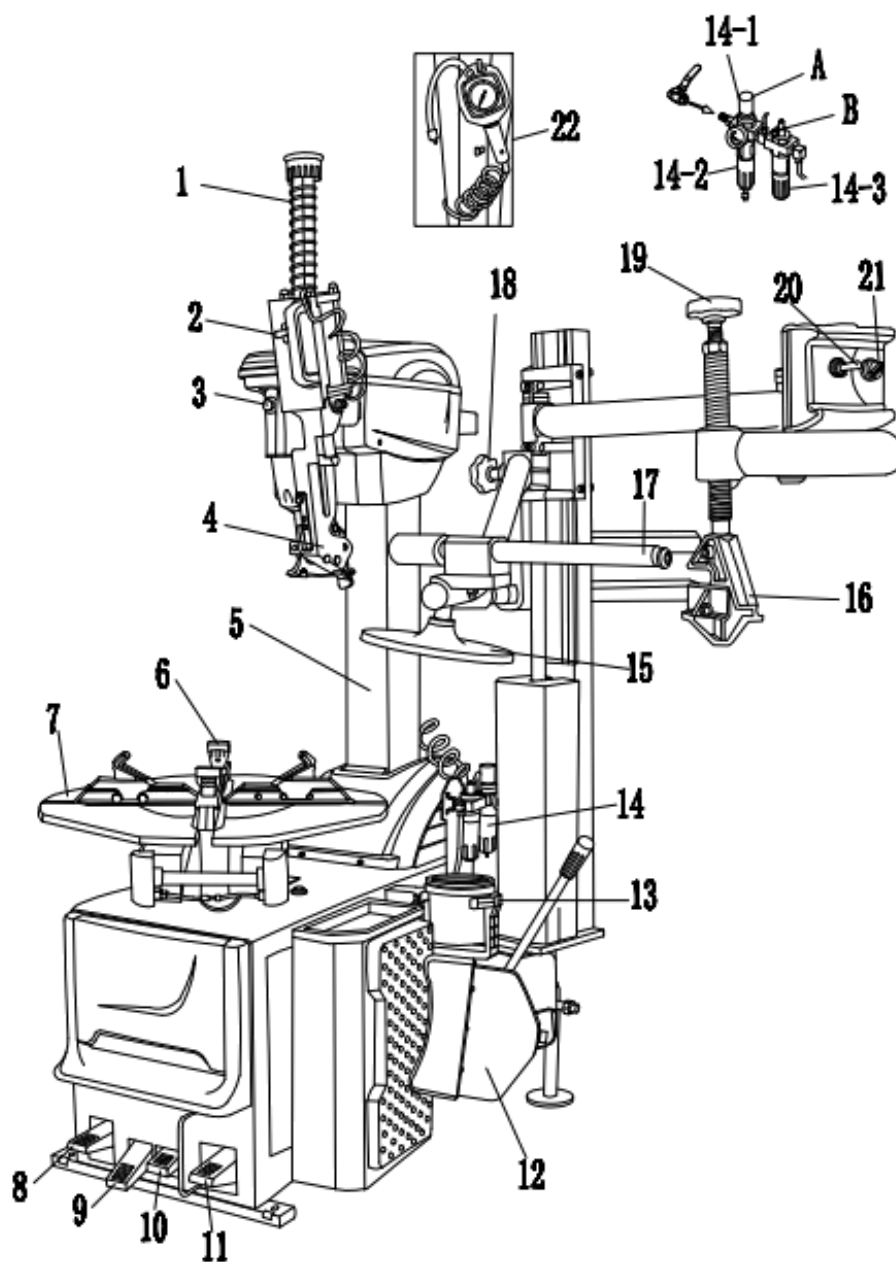

- **Machine structure**

- 1 Hexagonal shaft-----To fix working head
- 2 Control valve for automatic leverless system-----To control the leverless system moving.
- 3 Locking valve for horizontal arm-----To lock and unlock the hexagonal shaft and horizontal arm .
- 4 Automatic leverless system-----To demount and mount tyres.
- 5 Column-----To hold horizontal arm.
- 6 Clamping jaws -----To clamp rim.
- 7 Turntable-----To fix tyres
- 8 Pedal for tilting back-----To control the column tilting.
- 9 Pedal for clamping jaws-----To control the clamping jaws.
- 10 Pedal for bead breaker-----To control the bead breaker.
- 11 Pedal for turntable-----To control the turntable rotating.
- 12 Bead breaker-----To break the tyre bead.
- 13 Holder for lubricator -----To hold lubricator.
- 14 Air filter
- 14-1 Reducing valve-----To adjust the air pressure.
- 14-2 Water filter-----To separate the water from air.
- 14-3 Oil cup-----To supply oil to air route.
- 15 Lifting plate-----To lift the lower bead.
- 16 Pressing block-----To press the tyre bead.
- 17 Pressing roller-----To assist demounting and mounting tyres.
- 18 Handle-----To lock the press roller
- 19 Handle-----To adjust the height of pressing block
- 20 Control valve for helper-----To control the helper moving up and down
- 21 Locking valve for press roller-----Lock and unlock the pressing roller.
- 22 PCL inflation gauge-----To inflate the tyre

- **Machine nameplate**

Each machine is equipped with the nominated technical parameter and serial number



Warning

It is prohibited to detach the nameplate on the machine

- Each machine is equipped with the nominated technical parameter and serial number
 - V voltage supplied to the machine
 - A rated current when the machine is running
 - KW power
 - HZ frequency
 - PH phase of power supply
 - BAR operating air supply pressure
 - SEIAL N. machine's serial number
 - ISO 9001 certified management system
 - CE CE safety mark
- The completed information of machine model and serial number will be conducive for

our technical personnel to provide you with the service and technical support and also make it more accurate and easier to change the parts. If there is difference between the data in the manual and the data on the nameplate, the one on the nameplate should be considered to be correct.

Safety Requirement and Note

1. Use

This machine is used to demount/ mount the car tire. The dimension of the rim is 9"-26". The max diameter of the wheel can reach 950mm.

Any other usage will be incorrect.

Special statement: The manufacturer will not bear any responsibility to any damage arising from the operation not specified in the manual.

2. General safety precautions

- This machine can only be operated by the authorized personnel who have received special training.
- The manufacturer will not bear any responsibility to any direct or indirect damage arising from the modification to the machine without the permission of the manufacturer.
- When the machine is delivered out of the factory, it is equipped with the complete instruction manual and warning decal. If they are damaged or ruined for some reasons, please ask the manufacturer to change.
- The machine should be kept away from the inflammable and explosive materials. It should also be kept from sun and glare. The place to place the machine should be good ventilation.
- Make sure to use the original parts and accessories.
- The machine should be installed by the authorized personnel as per the manual.
- During operation, you should pay attention whether there is any danger. Once you find the danger, stop the machine at once and contact the dealers.
- When the machine is running, the unauthorized personnel should be kept away from the machine.
- The operator should wear the protective equipments such as gloves, goggle and overalls to prevent the accidental injury.



Warning

Secure that the grounding of the machine is perfect.



Warning

When operate the machine, the unauthorized personnel should be kept away from the machine.



Warning

Non-compliance to the operation requirement or the warning requirements related to the danger specified in the manual will cause the injuries to the operators or personnel nearby. Before connect the machine to the power supply, please carefully read the manual and warning notes. The machine must be operated by the profession personnel. The operator must have received special training and understood the requirement in the manual. He or she should also understand related safety requirement and detailed requirement in the process of operation. The operator must not run the machine after drinking.

The operator must pay attention to:

- Understand all the requirements specified in the manual;
- Understand the function of the machine;
- Unauthorized personnel should be kept from the machine;
- Secure the installation of the machine should comply with the related local law and regulation;
- Secure that the operators have received the training and have the skill to operate the machine. And they must be monitored;
- Do not detach the bolts, nuts or the other components from the machine;
- Before cut off the power supply, you must not contact the motor and the live parts on the machine such as power cord;
- Carefully read the manual and learn how to use the machine correctly and safely;
- Keep the manual for the future reference.



Warning

Do not detach the danger decals, safety warnings and operation tips on the machine. If there is any damage, please contact the local dealer in time.

- During the process of use and maintenance, the operator should pay attention to the danger of the high electrical voltage.
- Do not modify the machine or use the non-original parts unauthorized.
- The operators must wear tight overalls, gloves, goggle or safety shoes etc.



Warning

When operation or maintenance, it is forbidden to wear loose clothes, long hair or necklace.

TRANSPORT

1. Transport and packing

The machine should use the original package and then be transported. The package should comply with the following requirements:

- The package size requirement:

Width	1000mm
Length	1150mm
Height	1700mm

- The gross weight of the machine, meaning the weight of the machine plus carton: 420kg

2. Transport and storage environment requirements

Temperature -25°C--+55°C



Warning

Do not place any other objects on the carton.

3. Transport method

As shown in the Figure, detach the top package

Plug the fork of the forklift from bottom of the original package

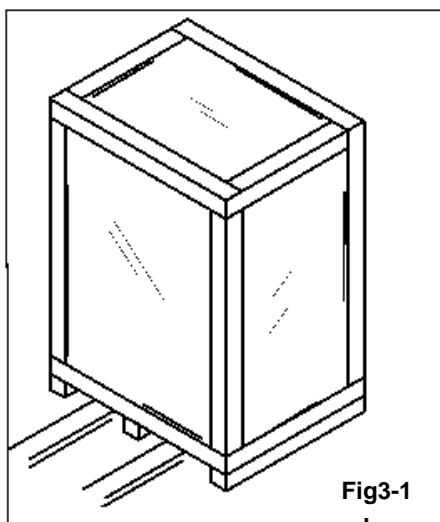

Note:

Keep the original package for the future transporting.

Unpacking

1. Unpacking

- When unpacking, the operator should wear the proper protective tool such as gloves.
- Carefully check the packing list of the machine to see if there is any mistake related to the quantity of the parts. If there is any mistake, please contact the dealer at once.
- The objects in the carton such as board, nails, screws and plastic bags should be located at the safe place.
- If there is any pollutant or the indecomposable substances, you should treat them as per the regulation specified in the local laws and regulations.



Warning

- During the process of unpacking, assembly and transporting, you should follow the following requirements and handle with care. Or it will damage the machine.
- Detach the upper cover of the carton and make sure whether there is any damage or not during transporting. Find the fix bolt to fix the machine on the pallet and prepare to shift out the machine.

2 Transports

- Hoist up the machine from the pallet. Bind the hoist tape (mod. DR 750 of 3m and DR 735 of 1.5m factor 6:1).
- No matter when to move the machine, you should take above methods.
- You can not move the machine if the machine is not cut off from its air supply and power supply.

Installation

1 Installation

- Installation environment requirement

Temperature	4-40°C
Sea level	<1000m
Humidity	50% 40°C-90% 20°C

- When you choose the installation position, you should secure the safety of the machine when it runs in the normal work condition.
- This machine must be connect to the mains and compressed air system, hence we suggest you to install the machine near the power source.
- Installation position should at least leave the space in the following figure to secure free movement of each part of the machine.
- If this machine is installed outdoors, you should take measures to prevent rain and sun. General speaking, this machine can not be used outdoors.
- The work are should enjoy enough light to secure the operators can observe each details of the operation.



Besides the operator, when the machine is running, any other personnel should not in the work area.

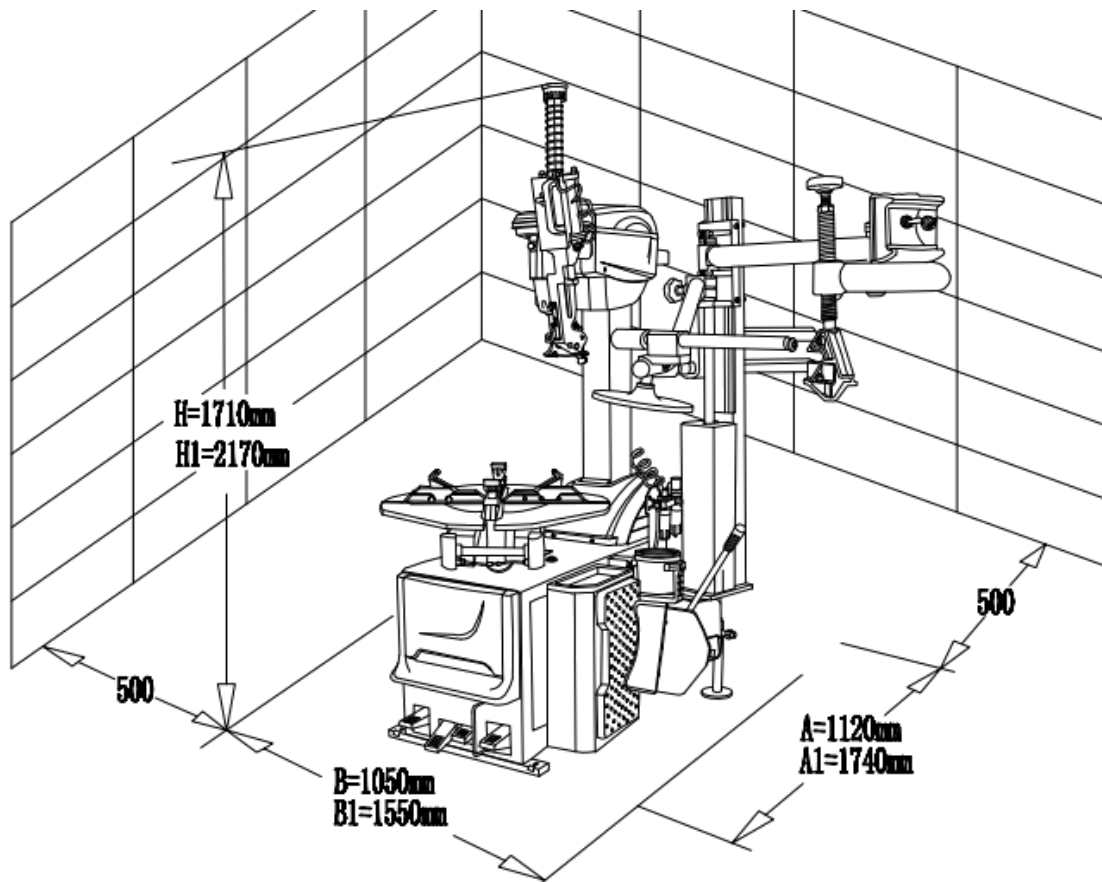

2. Fix of the machine

- Detach the bolts and nuts fixed on the machine chassis. Bind the hoist tape (mod. DR 750 of 3m and DR 735 of 1.5m factor 6:1).
Lift up the machine
- Take out the pallet and position at the preselected location.



Pay attention that the nozzle and air hose on the machine should not be damaged during the process of hoist. Pay more attention when hoist up the machine.



When inflate the tire on the turntable, you must fix the machine on the ground.

- Use the M10 bolt grade 12.9, via the hole at the pallet, to fix the machine on the ground.

3. The connection of the air supply and power supply to the machine

- Connect the machine to the electrical circuit. As per the electrical power specification, the electrical circuit must be equipped with the fuse and perfect grounded earth wire and also a protective switch will be connected.
- Note: If the machine is lack of the plug, the user should prepare a 16A plug adapted to the machine's operation voltage as per the electrical power norm.
- The voltage deviation should be 0.9-1.1 time of rated voltage range, And the frequency deviation should be 0.99-1.01 time of rated frequency range. You should take the necessary protective methods.

There must be professional personnel to be responsible for the connect of the electrical circuit.

- The electrical net in the working area should be reliable grounded.
- When you do not use the machine, please switch off the power supply in time to secure the machine not to be used accidentally.
- If the machine will not be used for a long time and the machine is directly connected to the electrical cabinet not via a plug. The electrical cabinet should be locked. Only the professional personnel can open to secure the machine not to be used accidentally.



Warning

The machine must be grounded and do not connect the earth wire to the heater, plumbing and telephone cable etc.

- Secure the compressed air supply comply the requirement of the machine. The details of these requirements are specified in chapter "technical parameter". The pressure and flow of the air supply should meet the requirement to use the machine. And the pressure ranges from 8 to 16 bar.
- Use the special air hose to connect with the water separator, air regulator and lubricator at the side of the machine. Please see the figure. Please make sure that the oil has been fully filled reaching the standard oil level. The oil contained in the lubricator should be SAE20 oil, or the air route will not be lubricated and the sealing kits will be damaged in a short time.

- The user must mount a air supply cut off valve and pressure regulation valve in front of the machine.

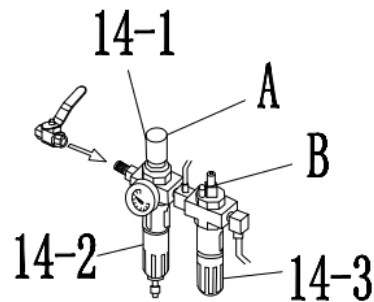

4. Test control system

Pedal control system

- Step down the turntable rotation control pedal 11, the turntable will rotate clockwise. And rise up the turntable rotation control pedal 11, the turntable will rotate counterclockwise.
- If the tire changer is equipped with the dual speed motor, step the turntable rotation control pedal 11 to the first gear and the turntable will rotate clockwise in low speed. And if step to the second gear, the turntable will rotate clockwise in high speed. And if we rise up the pedal, the turntable will rotate counter clockwise.
- Step down the horizontal arm control pedal 8 to the lowest position and the horizontal arm will swing out. And rise up the horizontal arm control pedal 8 to the highest position and the horizontal arm will swing back to the vertical position.
- Step down the blade control pedal 10, the blade will work and release the blade control pedal 10, the blade will back to its original position.
- Step down the clamping jaw open/close control pedal 9 to the first gear and the clamping jaw will open. Step down the clamping jaw open/close control pedal 9 to the second gear and the clamping will stop at any moment and Step down the clamping jaw open/close control pedal 9 to the third gear and the clamping jaw will close.
- If the horizontal arm at the inmost position, horizontal will be released and tool head will fall. When at the middle position, horizontal arm will be released and tool head will rise up.
- When at the outmost position, horizontal arm and tool head will be locked.
- Push upward the helper vertical movement control valve 20, the helper will move upward. Stop and the helper stops moving. Push downward the helper vertical movement control valve, the helper will move downward.
- Clockwise Pull the tire pressing roller lock button 21, the roller will be locked. Counterclockwise Pull the tire pressing roller lock button, the roller will be released.

Air treatment assembly

- Pressure reducing valve 14-1: Pull out the knob at the top end of pressure reducing valve. Clockwise/counter clockwise turning can adjust the feeding pressure of the

machine. Press down the knob A after adjustment.

- Water separator 14-2: Clockwise/counter clockwise turning knob B at the lower end of water separator can deflate the water in the water cup.
- Lubricator 14-3: Turning the knob at the top end of the lubricator. Clockwise/counter clockwise turning can adjust the oil feeding speed of the lubricator.

Note:

- The pressure of the machine should be adjusted in the range of 8-9bar.
- Regularly deflate the water in the water separator.
- Move back and forward the blade cylinder and observe the condition of lubricator. Guarantee the oil will be fed before operation each day.

Operation

1. Safety tip

- This machine is only used to mount/demount the car tires.
- The instruction manual must be correct. It is the integrated part of the machine.



Warning

- It is prohibited to use this machine to do the other work.
- The machine is equipped with the tire inflation system. This function is an independent one. You should pay more attention to this. Refer to the Chapter "inflation".



Warning You must use the original parts of the manufacturer.



Warning You should keep your hand far away from the point to be crushed.



Warning

When the accident appears, you should stop the running of the machine at once.

- **Plug out the power plug.**
- **Switch the air supply.**

2. Check before operation

- Each time before operate the machine, you should make the bead breaking cylinder run back and forward to observe the lubricator and make sure it starts feeding oil to the air route. After you confirm that the lubricator works normal, you can guarantee each part of the air route system under perfect lubrication.
- Check the air treatment assembly to guarantee the pressure indicated on the pressure gauge of the pressure reducing valve is not less than 8bar.
- Check whether the power supply connection is right or not.

3. Special note

- Some tires needs special process, different from the normal demount/ mount process.

- Some special rims as Fig 6-1, the groove at the middle of the rim is very shallow. Or there is no groove. These rim can not meet the safety regulation regarding the traffic and transportation. In some countries, these types of rim/Wheel are not allowed in the market.

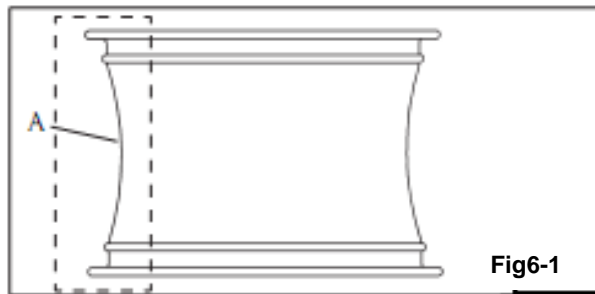

 **Danger**

Pay special attention when demount/ mount tire, rim or tire may be damaged.

- In the process of inflating the tire, the danger of tire burst may happen.
- The cross-section shaft of some rims is the smooth structure as Fig6-2. The C at rim is very deep. You will find B is higher than A. When you break the bead of this type of tire, you must press the bead which must be lower than B position. When mount the tire, the bead opposite to the tool head must over B point. At this moment, the bead can be led into the groove at the middle of the rim.

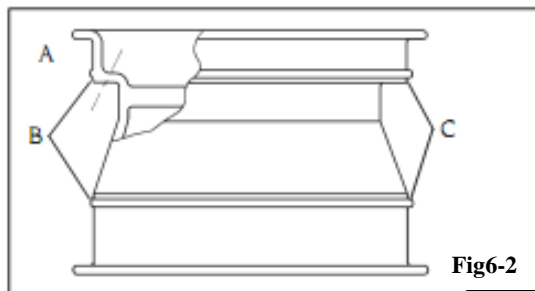

- Some wheels have the tire pressure inspect system as figure6-3. Do not damage the tire pressure inspect system.

4 Operation tips

 **Warning: The following information must be read. It will help the operator simplify the operation and avoid the unnecessary trouble.**

- It is very hard to rise up the stiff tire.
We suggest that the turntable should rotate counterclockwise. To the common tire, it can rotate clockwise.

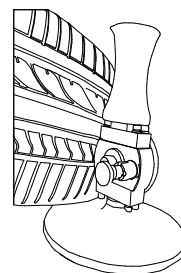

- When demount the upper side of the tire.
Due to the side of the tire is relatively smooth which can cause decoupling. So it is difficult to hook out the edge of the tire/ We suggest to rise up the lower bead. This can help hook out the bead.

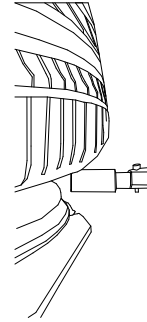

- When demount the upper side of the tire.
Due to the side of the tire is relatively smooth and the structure of the rim is special, the bead will come back into the rim. In this case, you can use the lower tire pressing disk to lift up the lower bead or position a small crowbar in front of the tool head as shown in the figure. Use the same method when demount the lower bead. Which can cause decoupling. So it is difficult to hook out the edge of the tire/ We suggest to rise up the lower bead. This can help hook out the bead.

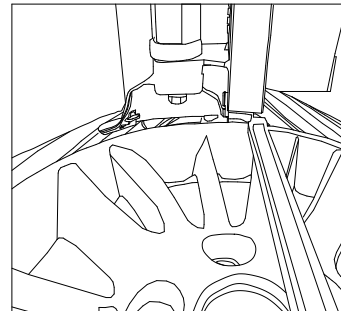

- When the hook hooks the upper bead, use the tire press opposite to the tool head to press down the bead. This can lead the bead into the groove of the rim. At this moment, the operator can use the crowbar.

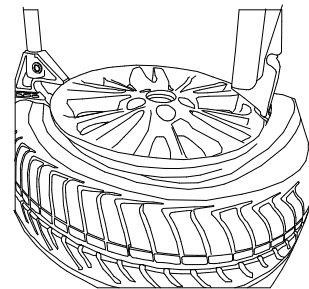

- If the hook moves downwards, it may damage the tire. You must use the tire pressing roller to press down the bead to make the space between bead and rim to allow the hook to come in. To the stiff tire, you can press the bead by tire press at the left side of the tool head.

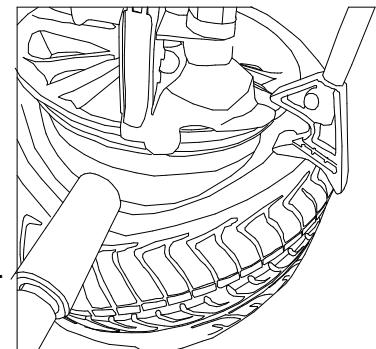

- When mount upper bead, at the left side of the tool head, use the tire press to press down the tire, meanwhile, add the bead clamp between the tool head and the tire pressing roller. This clamp can lead the bead into the groove of the rim.

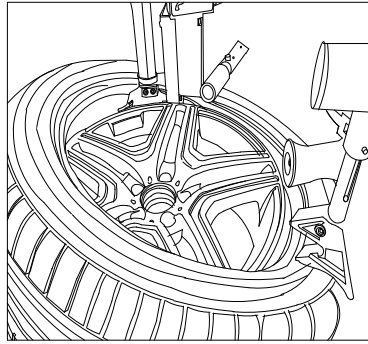

- To protect the rim, it is required that the plastic cover for the tool head should be once two months. If damaged, these plastic parts should be changed at once.

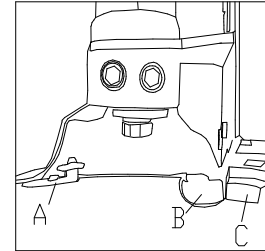

Warning

Bead breaking process is very danger, the operator should undertake in accordance with the instruction described in the manual.

5. Break the bead



Before any operation, please detach the weight attached on the wheel before and deflate the tire.



Not using the grease will seriously damage the tire. Please use the special grease.

- Check whether the tire has been deflated completely. If not, you should deflate at first.

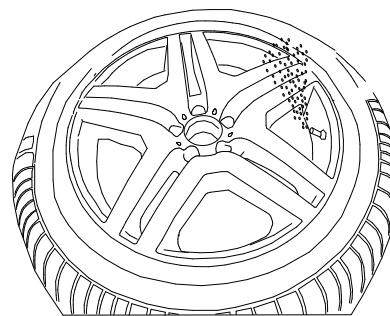

You should be very careful when you break the bead. When the blade moves, its speed is very fast and the strength is very strong. In the area of its moving, any objects will be under the danger of being crushed.

- The clamping jaw on the turntable should be closed completely.



When the clamping jaw is opened, if the operator undertakes bead breaking, this process will cause danger to the operator. In this process, the hand should not touch the pressed surface pressed of the tire.

- Lean the tire against rubber wheel support.
- The surface of the blade will keep about 1cm from the rim and the blade should rightly face the tire. Pay attention to the position of the blade to avoid it from touching the rim after bead breaking.
- Step down blade control pedal 10 to make the blade start working, When the bead is broken, release the pedal at once.
- Rotate the tire until the edge of the tire is detached from the rim and repeat at the other side
- Spread some grease on the tire.



Not using the grease will seriously damage the tire. Please use the special grease.

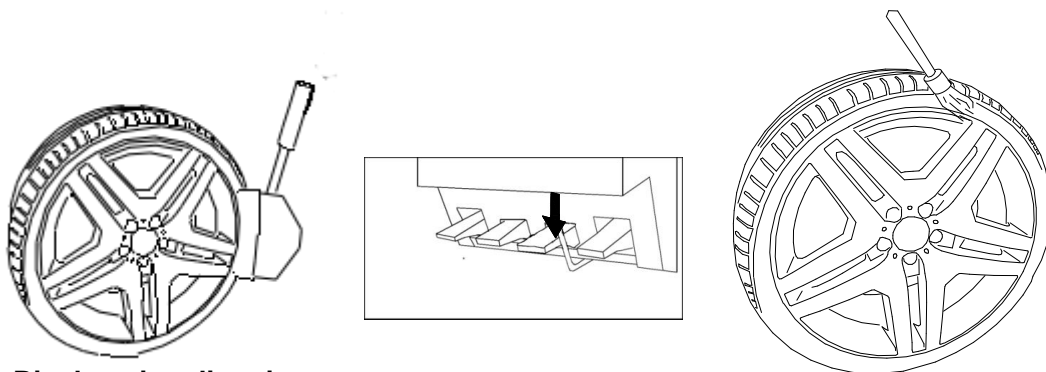

6. Rim location direction

- How to decide from which side of the wheel to demount tire? When fix the wheel, The side of standard rim will upward as figure, measure three dimension of A, B and C.
- When fix the rim, the smallest size of C must be positioned at the top position.

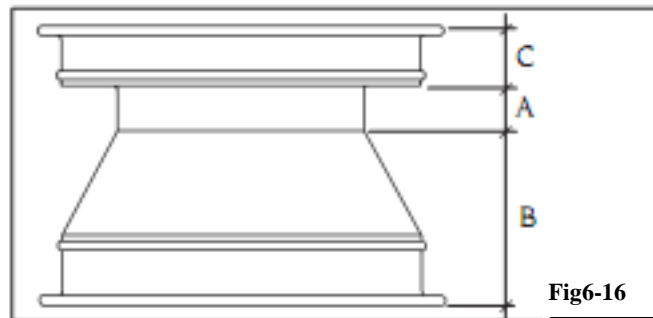

7. Fix tire



When the horizontal arm swings out, any one is forbidden in the range of its movement.

- Step down pedal 8, swing out the horizontal arm and clean the turntable.



When lock the tire, it is absolutely forbidden to put your hand under the tire. To correctly lock the tire, you should position the tire at the very center of the turntable.

Clamp the rim from outside:

- Through step down the clamping jaw open/ close pedal 9 to control the open position of the clamping jaw.
- Place the tire on the clamping jaw, keep pressing down the rim. Step down the pedal 9 until the rim is locked. The relative stiff tire, you can use tire presser to press down the rim to help fix the rim.



During you position the tire on the turntable, One operates is enough if the weigh is less than 25kg. If the weight is 25kg-50kg, 2 persons will be enough. And you will use the tire lifting device if the weight is more than 50kg.

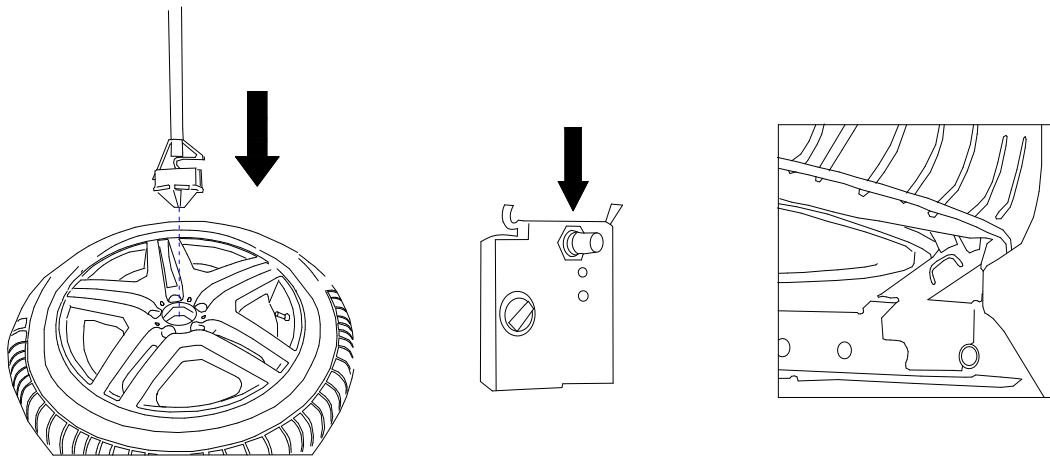

Clamp the rim from inside:

- Close the clamping jaw on the turntable.
- Place the tire on the turntable. Step down the pedal to open the clamping jaw until the rim is locked.



Secure the rim has been firmly locked on the clamping jaw.

8. Demount tire

Position the tool head

- Use the tire pressing roller to press the upper bead to leave the space for positioning the tool head.
- Step down the horizontal arm swing out pedal to move the horizontal arm to the work position.
- Push the horizontal lock plate button to release the hexangular shaft.
- Move the tool head to the work position. The plastic part at the head of the tool head should contact with the rim.
- Push the horizontal lock plate button to lock the hexangular shaft.

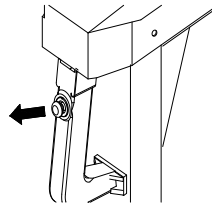
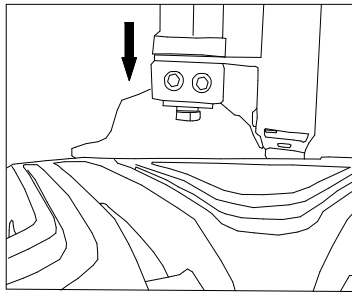
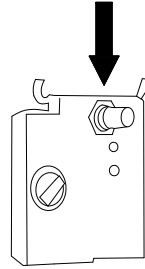
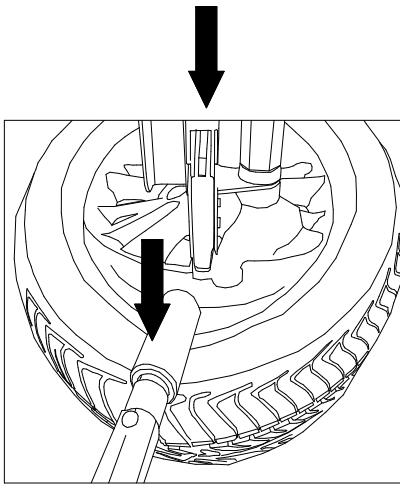

Hook out the upper bead

- Hold on the tire pressing roller to leave the space for the tool head.
- To hook out the upper bead, you can use the tire pressing roller to lift up the bottom bead, while lead the bead into the groove of the rim,
- Secure the upper bead has been hooked by the tool hook completely.
- Handle the hook moving press button to hook out upper bead. Note: at this moment, the tire should not rotate.

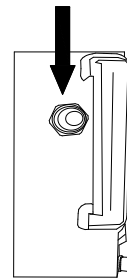
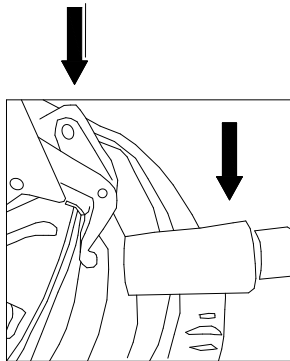

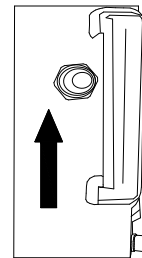
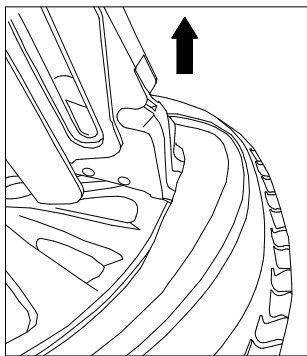
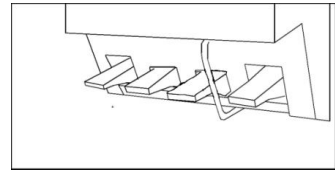
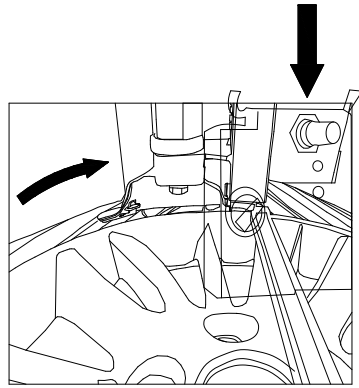
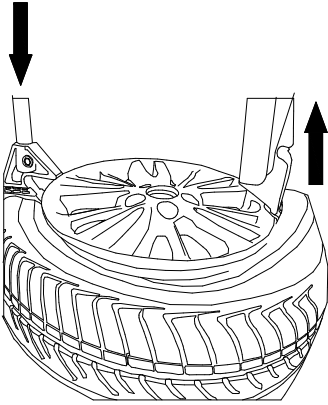
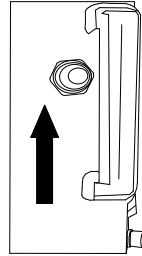
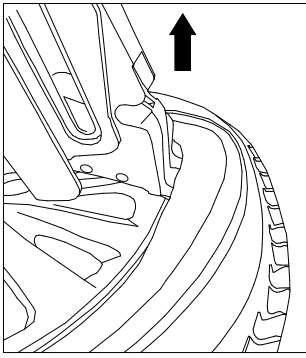

Demount the upper bead

Step down the pedal 11 and rotate the wheel until upper bead is completely detached from the rim.

In this process, you can rise up the lower bead to help demount the upper bead.

During this process, if the bead slip back into the groove of the rim, you can take the measures described in Chapter "operation tip" to demount the upper bead

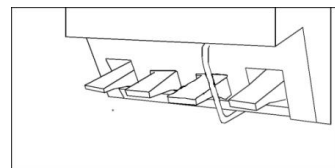
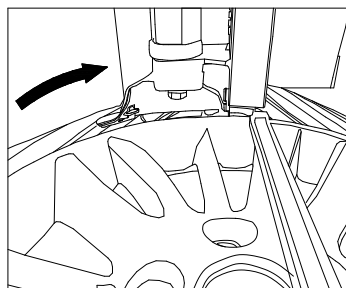
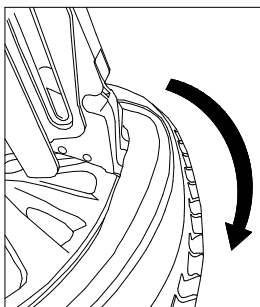

Demount the lower bead: Use the tool head to demount.

- If there is tube inside the tire, remove it.
- Repeat the same process described above until detach the lower bead.
- Use the roller to rise up the lower bead
- Handle the hook moving press button to hook out upper bead. Note: at this moment, the tire should not rotate.
- Step down the pedal 11 and rotate the wheel until upper bead is completely detached from the rim.

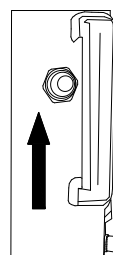
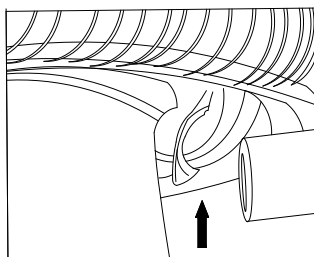
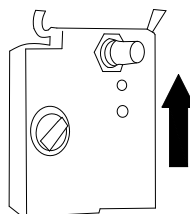
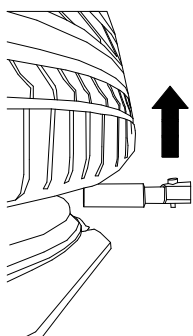

Detach the lower bead: Use the lower tire pressing disk to demount

- Use the tire pressing roller to rise up the bead until it is higher than the upper end of the rim.
- Step down the pedal 11 to rotate the wheel until the upper bead is completely detached from the rim.

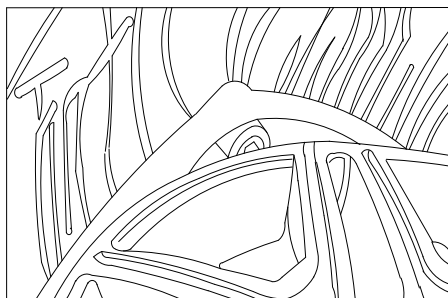
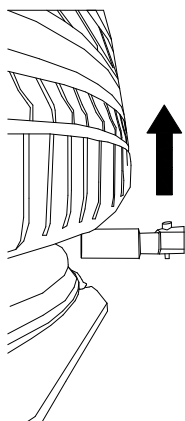

- **Shift out the tire**

Swing out the horizontal arm and shift out the tire.

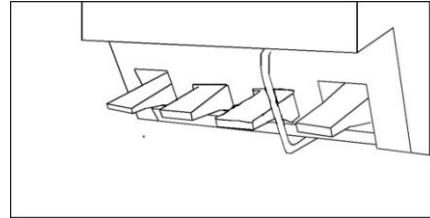
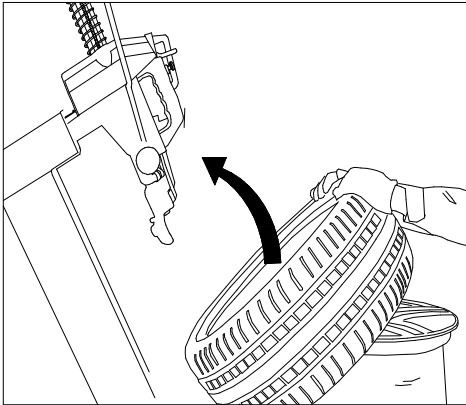

9. Mount the tire

Selection of the tire

Before select the tire, you should know the technical feature, technical parameter, characteristic and safe grade of the tire. The related information is marked on the side wall of the tire.



Note

Before mount the tire, please change the core of the nozzle to be the nozzle of tubeless tire.



Note

Confirm whether the related parameter of the tire matches the parameter of the rim or not. And also make sure the rim is not deformed and the center hole not damaged. While you should also secure that the surface of the rim without the phenomenon of rusty and broken and there is not any bur at the nozzle.

Confirm the tire is under perfect condition and without any damage.

Prepare the tire

- Lubricate the bead with the special tire grease.
- Place the tire on the rim with the tilt angle of 45 degree.

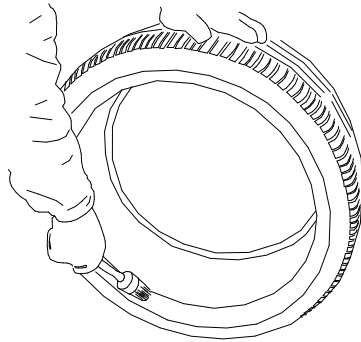

Position the tool head

- Step down the pedal 8 to move the tool head to the work position.

Note: If you do not change the rim, the tool head will automatically back to the correct working position.

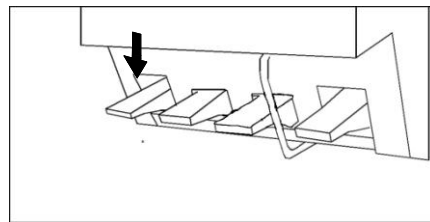
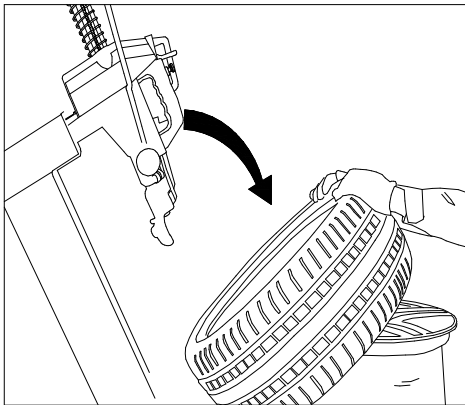

Mount the bottom bead

- Position the bottom bead at the bottom end of the head of the tool head, while at the top end of the tail of the tool head.
- Use your hand to slightly press the tire to lead the tire into the groove of the rim.
- Clockwise rotate the tire to mount bottom bead.

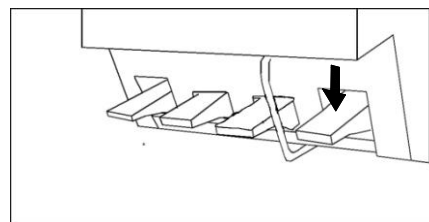
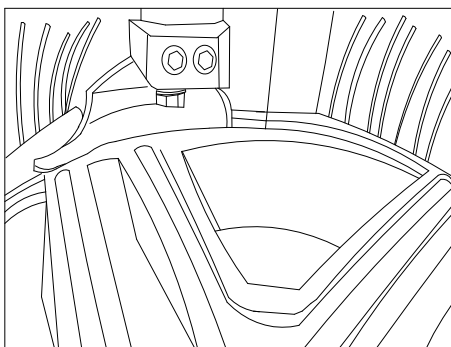

Mount the upper bead

- Position the upper bead at the bottom end of the head of the tool head, while at the top end of the tail of the tool head.
- Use the tire pressing roller to press bead to lead to the tire into the groove of the rim.

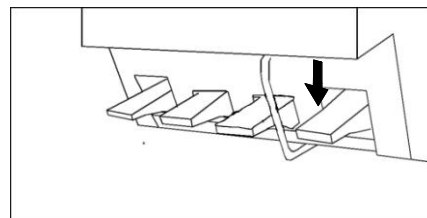
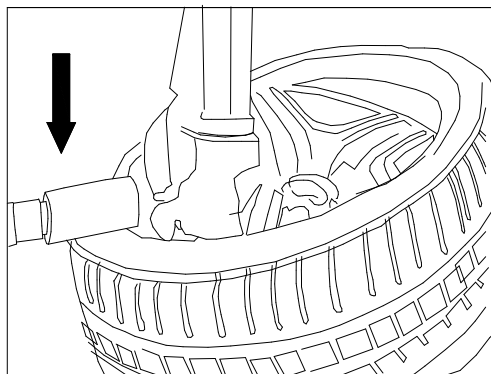

The bead can not slide out of the head of the tool head.

- Use the tire press to press the upper bead
- Rotate the turntable to mount the upper bead until the tire press approaches the tool head
- Step down pedal 8 and move out tool head
- If the size of the rim is larger than 19", you can use the bead clamp. It is convenient to mount the bead and can avoid damaging the rim
- Rise up the tire press

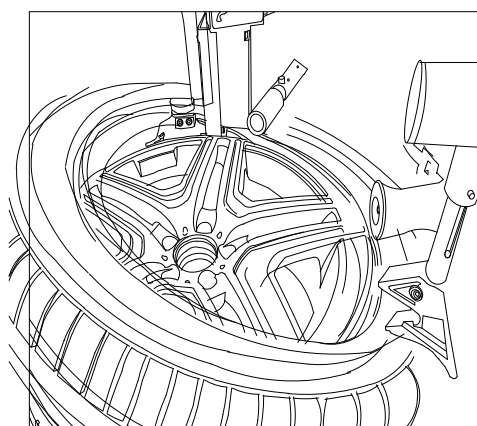

Note: When you mount/ demount the tire, tire rotates clockwise. If the tire is jamming during the process, please stop working and counterclockwise rotate the tire to remove the jamming.

Do not place your hand on the tire. When the hexangular shaft comes back to its work position, the hand between the rim and the tool head may be crushed. Remove the objects may cause the danger to the operators



such as bracelet and loose cloth etc. To avoid the accident, when the turntable rotates, you should keep your hand and the other part of your body away from the tool head as far as possible.

10. Mount/ demount the special wheel

- Some special rims, the groove at the middle of the rim is very shallow. Or there is no groove.

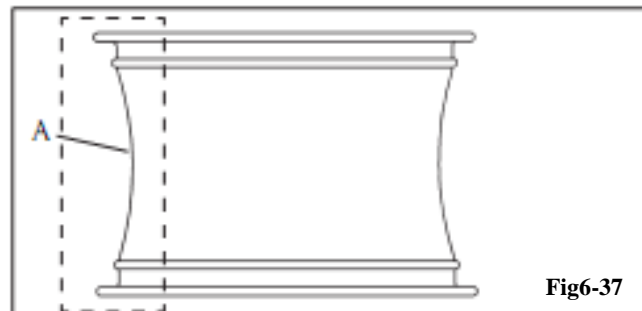

- To these rims, the operator should find the best position to hook to decrease the resistance.

11 DEMOUNT AND MOUNT RUN FLAT TIRE WITH VALVE SENSOR

- **Demount the tire**
 - Confirm the wheel has the valve sensor
 - Take out the core in the nozzle and deflate the air inside the tire
 - Note: If necessary, detach the nut on the valve and push the sensor into the tire.
 - Position the sensor at the 3o'clock position
 - Use the blade to break the bead and lubricate the bead until the sensor goes to the 12o'clock position
 - Rise up the blade
 - Position the sensor at the 6 o'clock position (nozzle at 12 o'clock position)
 - Press down the bead and clamp the bead clamp at 2 o'clock position
 - Break the lower bead



- Rotate the wheel, making the bead clamp at 2 o'clock position
- Position the tool head
- Rotate the tire and the tire clamp will go to 6 o'clock position and the sensor is at 10 o'clock position
- Hook out the bead and clockwise rotate the tire.
- Break the upper bead and move out the bead clamp
- Break the lower bead but pay attention that you should not damage the sensor

● **Mount the tire**

- Mount the valve sensor if it has been moved out
- Lubricate the bead
- Position the sensor at 5-6 o'clock position
- Tilt the tire by 45degree and position the tool head. Use your hand to rotate the tire making it contact with the tool head at the correct position
- Rotate the rim and mount the upper/lower bead
- Rotate the wheel and position the sensor at 4-5 o'clock position
- Press down the blade and position the bead clamp at 3 o'clock position
- Press down the blade, tire and wheel, 50mm lower than rim
- Rotate the rim and at this moment adjust the position of the blade, tire and wheel until the bead has been mounted.
- If necessary, press the tire press between the bead clamp and the wheel to press the bead
- Move out the tool head and take out bead clamp.

12 DEMOUNT AND MOUNT RUN FLAT TIRE WITH BUNDLE & PASTE TYPE SENSOR

● **Demount the tire**

- Note: The correct position of the sensor should be 180degree to the nozzle
- Take out the core in the nozzle and deflate the air inside the tire
- Confirm the correct position of the sensor.
- Position the sensor at the 3o'clock position. And the position of the nozzle is at 9 o'clock position
- Use the blade to break the bead and lubricate the bead until the sensor goes to the 12o'clock position and the nozzle is at 6 o'clock position
- Rise up the blade
- Position the sensor at the 6 o'clock position (nozzle at 12 o'clock position)
- Press down the bead and clamp the bead clamp at 2 o'clock position
- Break the lower bead
- Rotate the wheel, making the bead clamp at 2



o'clock position. (Sensor at the 6 o'clock position and the nozzle at 12 o'clock position)

- Position the tool head
- Rotate the tire and the tire clamp will go to 6 o'clock position and the sensor is at 10 o'clock position and the nozzle at 4 o'clock position)
- Hook out the bead and clockwise rotate the tire.
- Break the upper bead and move out the bead clamp
- Break the lower bead but pay attention that you should not damage the sensor

● **Mount the tire**

- Mount the valve sensor if it has been moved out
- Lubricate the bead
- Position the sensor at 2-3 o'clock position and nozzle at 8 o'clock position
- Tilt the tire by 45 degree and position the tool head. Use your hand to rotate the tire making it contact with the tool head at the correct position
- Rotate the rim and mount the upper/lower bead
- Rotate the wheel and position the sensor at 4-5 o'clock position and nozzle at 10 o'clock position
- Press down the blade and position the bead clamp at 3 o'clock position
- Press down the blade, tire and wheel, 50mm lower than rim
- Rotate the rim and at this moment adjust the position of the blade, tire and wheel until the bead has been mounted.
- If necessary, press the tire press between the bead clamp and the wheel to press the bead
- Move out the tool head and take out bead clamp.

Inflation

1. Warning



Warning: The explosion may cause serious damage to the operator even death. So you should be more careful and strictly follow the following use instruction. For the reason that some protective devices are not designed and manufactured, the operator must wear the goggles and related protection.



Note

During operation, the noise may reach 85dB(A), so the operator should wear the related protective devices.



Danger

The machine is equipped with inflation pressure limit valve, but if the condition of tire and rim is not good or the operation is incorrect, there is still the possibility of tire burst.



Danger

Do not exceed the max pressure nominated by the manufacturer.

During the process to inflate, the operator should keep away from the tire as far as possible.

- Carefully check if the size of the rim is same to the size of the tire.
- Check the wear state of the tire or whether there is damage or not.
- During the process to inflate, frequently check the pressure inside the tire.
- The hand and body should be kept away from the tire.

2. Inflate tubeless tire

- Secure the rim is firmly fixed on the turntable and the tool head and the tire pressing disk has been kept from the tire. If possible, it should be positioned to the farthest point.
- Mount a new nozzle at the rim.
- Secure the tire has been completely lubricated.
- Take out the cup of the nozzle and clamp the gun at the top end of the core to inflate the tire.
- Frequently stop inflation and check the pressure inside the tire, not exceeding 3.5bar, until the pressure inside the tire meet the requirement and avoid the tire pressure not exceeding the max pressure.
- Tubeless tire needs relatively large air flow. If air flow is not enough, the bead should not transit the hump. To increase the air flow, you can take out the core of the nozzle. As figure, it is very good for the safety of the car when in runs on the road.

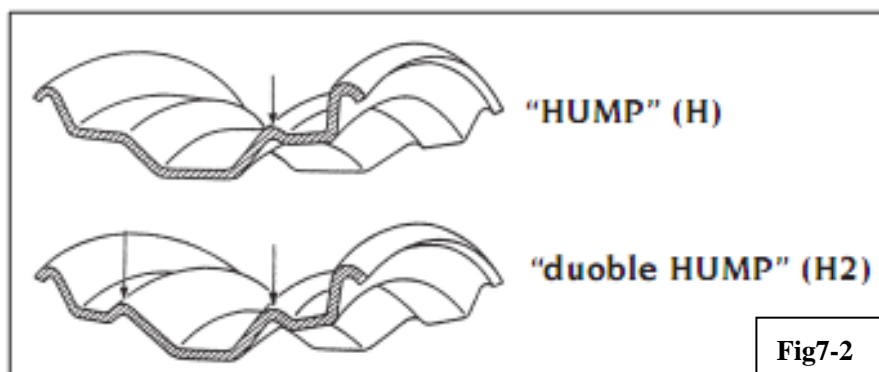

- Check. The junction between the bead and rim must be perfect. If there is problem, you must deflate the tire and repeat breaking bead and lubricate the bead. Rotate the tire and then inflate the tire.
- Attach the core to the nozzle.
- Connect the inflation gun and then press the deflate button to remove the residual air.
- Mount the nozzle.

3. Inflate the tire with tube

- Secure the rim is firmly fixed on the turntable and the tool head and the tire pressing disk has been kept from the tire. If possible, it should be positioned to the farthest point.
- Mount a new nozzle at the rim.
- Secure the tire has been completely lubricated.
- Take out the cup of the nozzle and clamp the gun at the top end of the core and step down the inflation pedal to inflate the tire.
- Push the nozzle on the tube to deflate the air between the tube and tire. Or the tube will be damaged.
- Frequently stop inflation and check the pressure inside the tire, not exceeding 3.5bar, until the pressure inside the tire meet the requirement and avoid the tire pressure not exceeding the max pressure.
- Attach the core to the nozzle.
- Connect the inflation gun and then press the deflate button to remove the residual air.
- Mount the nozzle.

4. Tire pressure

- Securing the correct tire pressure is very important to the safety of the wheel.
- The low tire pressure will cause the tire to be too heat and with serious wear. And the life of the tire will be shortening. The inside of tire will be damaged and the oil consumption will be larger.
- The high tire pressure will cause easy damage when clamping and the tire wall will be seriously worn.
- You must check you tire pressure one a week. You should prepare a spare tire before you start a long distance journey.
- Check the tire pressure under the normal tire temperature, not check when the tire temperature is too high or too low.
- Normal tire temperature means the vehicle has not run for more than one hour or the run for not more than 2-3km in low speed.
- The tire pressure under normal tire temperature should meet the requirement of the car and the tire producer.
- When the can is under heavy load, if the tire pressure are not special specified, normally speaking, the tire pressure will increase by 0.3bar.

Transport

- Switch off the air supply switch and power supply switch.
- Transport the machine as per the method in chapter"unpacking"



Note: When you hoist the machine, you should not damage the nozzle and air hose on the machine. Pay mote attention to the process of hoisting machine.

Storage



If you want to store the machine for a long time, you must secure

- Switch off the air supply and power supply and lubricate the movable parts to prevent rusting.
- The storage temperature is -25°C ---- 55°C
- The machine should be kept away from the inflammable and explosive materials. It should also be kept from sun and glare. The place to store the machine should be good ventilation.

Ruin



If you want to ruin the machine, you must secure

- Switch off the air supply and power supply.
- Remove all the non-metal substances and treat them as per the local law and regulation.
- Collect the oil and treat them at the pointed place as per the local law and regulation.
- Ruin the other metal substances.

Environment



The machine contains some substances which will pollute the environment and cause the damage to the human body if they are not treated properly.

Maintenance

1 Warning



Non-professional personnel should not undertake maintenance.

- As per the description in the manual, undertake the maintenance periodically. This is very necessary to prolong the life of the machine and guarantee the normal work condition of the machine.



If you do not undertake the periodical maintenance, the reliability and operation of the machine will not get guarantee and may cause danger to the machine, operator and the people nearby.



Before undertake any maintenance, you should switch off the air supply and power supply. By repeating stepping down the pedal, you can deflate the residual air in

the machine completely.

- The fault parts must be changed by the original parts provided by the manufacturer.

 Removing or breaking the safety devices such as safety valve and standard nozzle violate the safety standard.

 Special note: The manufacture will not be responsible for the claim arising from the apply of the parts supplied by the other supplier and the damage caused by removing or breaking the safety devices.



You should not modify the component on the machine without authorized.



Note:

Keep the working area clean.

Do not use the compressed air to blow off the debris on the machine. Reduce the coming out of the dust around.

2 Maintenance operations

Do the following operation at least one time per 30days.

- Check the oil level in the oil cup 14-3. If the oil is not enough, remove the oil cup and fill the lubrication oil as shown. The oil filled in the lubricator must be the special SAE20 oil.
- The oil feeding speed regulation: Make the bead breaking cylinder run back and forward to check whether the oil feeding speed is one drop of oil per 2 travel of the cylinder. If not, use the bolt B to adjust.
- Drainage: Check the water quantity in the water cup. Turn/ press at the low end of the water cup to drain.
- Each time before operate the machine, you should make the bead breaking cylinder run back and forward to observe the lubricator A and make sure it starts feeding oil to the air route. After you confirm that the lubricator works normal, you can guarantee each part of the air route system under perfect lubrication.

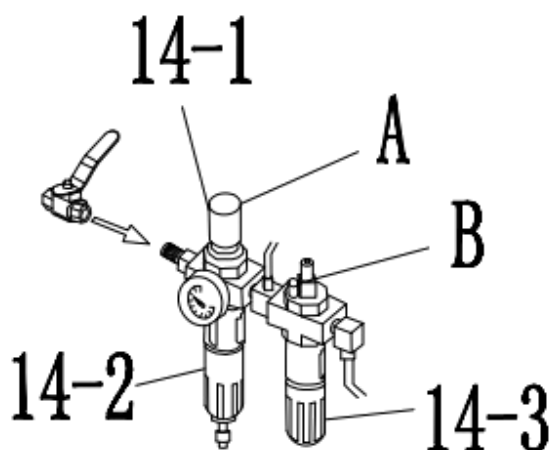

- Periodically tighten the nut at the fixed equipment.
- Periodically fill in the lubrication oil components can move and slide to each other.
- Periodically adjust the tension of the motor belt as per the following steps:
 - Before this operation, switch off the power supply and air supply.
 - Detach the side panel on the machine cabinet.
 - Release the bolt A and nut C. Adjust the adjust bolt B at the back end of the motor bracket. Tighten the belt. The requirement to the tension of the belt is that the belt will move inward by 8mm if you apply the force of 8kg.
 - After adjust, position the belt and tighten bolt A and tighten nut C.

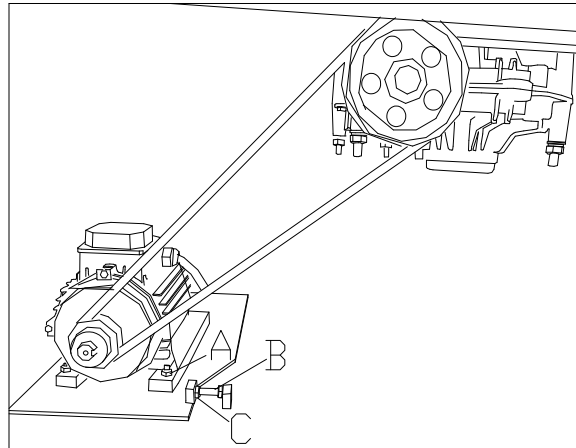

- If the tool head is not locked or not located at the position 2-3mm higher than the rim, it is necessary to adjust the adjusting nuts A and B at the front end of hexangular shaft lock plate.

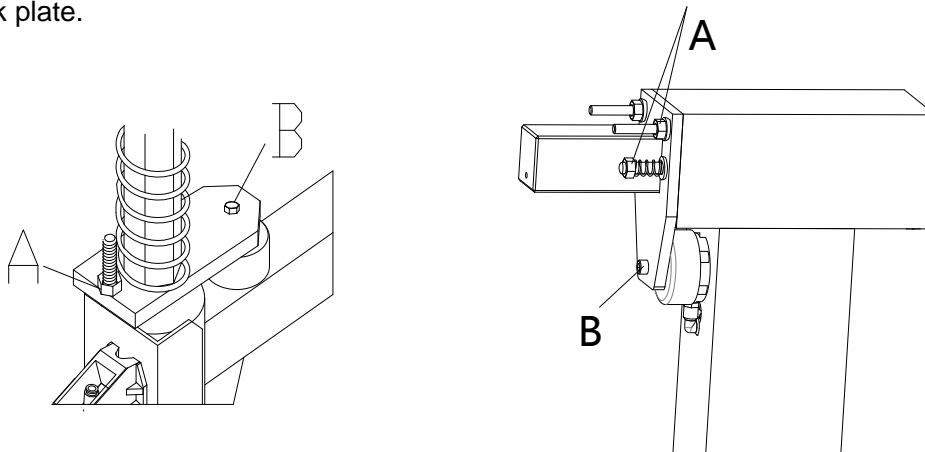

- If the tool head is not locked or not backward by 2-3mm, it is necessary to adjust the adjusting nuts A and B at the front end of quartet lock plate.
- If the lifting device moves too slow and the column tilts too slow, you should operate as per the following steps shown. Clean the silencer.
 - Before any operation, switch air supply and power supply.
 - Detach the side panel on the machine cabinet.
 - Adjust the silencer A and B on the adjust valve assembly.
 - Or use the high pressure air to clean. Change the silencer if it is damaged.

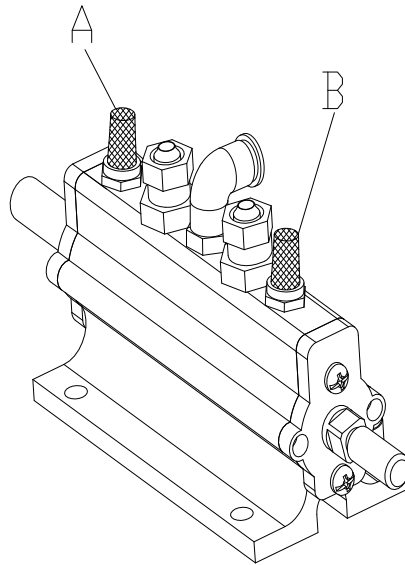

3. Use of the oil

- Treatment of waste oil: Do not expose the waste oil can be volatile to the air or directly drop into the sewer/ river. You should dispatch it to the professional treatment company to treat.
- Oil overflow and leakage: Prevent the oil from entering into the soil, sand or any other absorbent. To the residual oil, you must use the cleaning substances can solute oil to treat. The cleaning agent must comply with the local law and regulation requirements.
- Warning to use the oil
- Avoid direct contacting the skin.
- Do not let the oil form oil fog and diffuse into the air.
- **We must meet the following safety requirement**
 - Avoid the oil from splashing and touching the skin, the surface of machine and protective cover of the machine.
 - Often use wash and soap to use your hand. Do not use the detergent stimulating skin and subjects harmful to the skin.
 - Do not use the rag to clean your hands.
 - Do not wear the oily clothes, while you must change the working suit after finished the work.
 - Do not smoke and eat with the oily hand.
- **Meanwhile, take the following measures**
 - The gloves should be oil-proof.
 - Wear goggle to prevent the splash of the oil.
 - Wear aprons to prevent the oil.
 - Apply protective screen to prevent the splash of the oil.
- It is forbidden to inhale, swallow of oil. And forbidden the splash of the oil and prevent oil from touching skin.
- Firefighting material

- As per the following table

	Solid	Liquid	Electrical equipment
Water	yes	no	no
Foam	yes	yes	no
Dry powder	Yes”	yes	yes
CO2	Yes”	yes	yes

Yes” The material used should be used by the professional firefighting



Note:The above information is only for the purpose to provide the user with the basic guidance. The detailed information should contact the fire management agency.

Troubleshooting solution



All the problems should be checked and solved by the professional personnel. If you have no professional personnel, you must contact the dealer to get the related technical service for fear of wasting time.

- **Turntable cannot rotate**

Short circuit

- Check cable of motor
- Change motor
- Check the plug
- Check the reversing switch/ change reversing switch
- Check the driven parts of the reversing switch
- Adjust the belt/ change the belt

- **The pedal can not back to its original position**

The spring is damaged.

- Change the spring.

- **Bead blade can not break the bead**

The cylinder sealing kits is worn

- Change the sealing kits
- Change the new cylinder

- **Air leakage at the center of the cylinder**

The cylinder sealing kits is worn

- Change the sealing kits
- Change the cylinder

- **Worm case can not work or the noise is too much**

The worm case assembly is damaged.

- Change the worm case.

- **The turntable can not fix the rim**

The turntable cylinder is damaged

- Change the turntable cylinder
- Change the turntable cylinder sealing kit
- **The torque is not enough when demount/ mount the tire**

The tensile force of the belt is not enough and the bead can not be led into the groove of the rim.

- Adjust the belt.
- Change the motor capacitor
- Change the motor
- Use the tire pressing help to lead the tire into the groove of the rim while keep full lubrication on the bead.
- **When lock the tool head, the distance between the tool head and the rim should not be too far or too near**

Lock plate releases for the bad adjustment.

- Adjust the lock plate bolt at the back end of the hexangular shaft
- Adjust the lock plate bolt at the back end of the horizontal arm
- **The vertical movement of the hexangular shaft is not smooth**

The lock plate does not work

- Change the lock plate.
- The bolt at the lock plate is released.
- Adjust the hexangular shaft lock plate.
- **The tool head can not lock for the tool head move too much in the process of demount/mount tire and the rim is easy to be damaged**

Lock cylinder is damaged, there is wear at the sliding position of horizontal/ vertical arm and without air to flow in.

- Change the lock cylinder sealing part
- Change the lock cylinder
- Adjust the bolt at the lower part of the horizontal arm, making the clearance between the horizontal arm bushing and hexangular shaft narrower.
- Adjust the bolt at the front end of the vertical arm, making the clearance between the horizontal arm bushing and quartet shaft narrower.
- Adjust the lock plate.
- **The vertical arm can not swing out or too slow**

Vertical arm control air route with problem

- Change vertical arm cylinder sealing kits
- Change vertical arm cylinder
- Check whether there is bending at the air hose
- Check whether there is air leakage at the vertical arm tilt back control pedal valve.
- Change the pedal valve.
- Adjust the air flow at the nozzle on the adjust valve.
- **Tool head cylinder air leakage/ hook without force**

The cylinder piston is damaged/ sealing kits is broken

- Change the cylinder piston
- Change the sealing kits of the cylinder
- Change the cylinder

- The pressure gauge does not zeroing

The pressure gauge is damaged

Change the pressure gauge

PNEUMATIC SCHEME

