

Version: 717

Serial No.: _____

Production Date: _____

USER'S MANUAL

PORTABLE MID-RISE SCISSOR LIFT

MODEL: 8030P

TABLE OF CONTENTS

PACKING, TRANSPORTATION AND STORAGE.....	1
MANUAL INTRODUCTION.....	1
1. DESCRIPTION OF THE MACHINE.....	2
2. SPECIFICATION.....	2
3. SAFETIES.....	6
4. INSTALLATION AND DEBUGGING.....	8
4.1 INSTALLATION.....	8
4.2 DEBUGGING.....	9
5. OPERATION.....	10
5.1 OPERATION NOTICE.....	10
5.2 CHECK BEFORE OPERATION.....	10
5.3 OPERATION PROCEDURE.....	10
5.4 WORKING PRINCIPLE OF LOCKING MECHANISM.....	11
6. MAINTENANCE AND CARE.....	12
7. TROUBLE SHOOTING GUIDANCE.....	13
EXPLOSIVE DRAWING.....	14
PARTS LIST.....	16
WARRANTY.....	17

(Blank Page)

PACKING, TRANSPORTATION AND STORAGE



ALL PACKING, LIFTING, HANDLING, TRANSPORT AND UNPACKING OPERATIONS ARE TO BE PERFORMED EXCLUSIVELY BY EXPERT PERSONNEL.

PACKING

Standard equipment:

Platform (1# CTN), power pack, trolley and accessories (2# CTN) total is 2 pieces.

Packing dimension picture (*Fig. 1*)

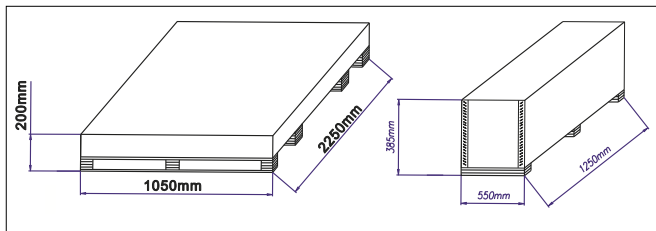

Fig. 1 Packing Dimension

Packing list:

Plywood box with lift frame assembly and hydraulic hose x 1 unit

Plywood box with power unit and dolly x 1 unit

Arm adapters x 4 pieces

Height adapters x 4 pieces

Rubber height adapters x 4 pieces

Installation instructions x 1 unit

TRANSPORT



Packing can be lifted or moved by lift trucks, cranes or bridge cranes. In case of slinging, a second person must always take care of the load, in order to avoid dangerous oscillations.

During loading and unloading operation, goods must be handled by vehicles or ships.

At the arrival of the goods, verify that all items specified in the delivery notes are included. In case of missing parts, possible defects or damage due to transport operations.

If finding missing parts, possible defects or damage due to transport, one should examine damaged cartons according to **Packing List** to verify the condition of damaged goods and missing parts, also the person in charge or the carrier must be immediately informed.

The machine is heavy goods! Don't take manpower load and unload and transporting way into consideration, the safety of working is important.

STORAGE

- The machine equipment should be stocked in the warehouse, if stocked outside should do the disposal well of waterproof.
- Use box truck in the process of transport, use container storage when shipping.
- The power pack should be placed perpendicularly during the transport; and prevent other goods from extrusion.
- The temperature for machine storage: -25°C-55°C

MANUAL INTRODUCTION



This manual has been prepared for workshop personnel expert in the use of the lift operator and technicians responsible for routine maintenance fitter.

Workers should read the **User's Manual** carefully before carrying out any operation with the lift. This manual contains important information regarding:

- The personal safety of operators and maintenance workers.
- Lift safety.
- The safety of lifted vehicles.

CONSERVING THE MANUAL



This manual is an integral part of the lift. The manual must be kept in the vicinity of the lift, so that the operator and maintenance staff must be able to locate and consult the manual quickly and at any time.

Attentively reading Chapter 3, which contains important information and safety warning, is particularly recommended.



The lifting, transport, unpacking, assembly, installation, starting up, initial adjustment and testing, extraordinary maintenance, repair, overhauls, transport and dismantling of the lift must be performed by specialized personnel from the licensed dealer authorized by the manufacturer.

The manufacturer declines all responsibility for injury to persons or damage to vehicles or objects when any of the above mentioned operations has been performed by unauthorized personnel or when the rack has been subject to improper use.



This manual indicates: the operative and safety aspects that may prove useful to the operator and maintenance worker. For better understanding the structure and operation of the lift and for best use of the same, workers must read the User's Manual carefully before carrying out it.

In order to understand the terminology used in this manual, the maintenance and repair activities, the ability to interpret correctly the drawings and descriptions contained in the manual and be the country in which the machine has been installed.

The same applies to the maintenance and the maintenance fitter must also possess specific and specialized knowledge both in mechanical and engineering field.

OPERATOR: person authorized to use the lift.

MAINTENANCE FITTER: person authorized for routine maintenance of the lift.



Manufacturer owns the right to make little change for the manual owing to the improvement of technology.

1. DESCRIPTION OF THE MACHINE

Machine Application:

8030P portable mid-rise scissor lift can lift cars, vans and light-duty trucks whose weight is less than 3000kg, which is ideal for tyre, wheel and brake related repairs, collision repair work and new car preparation.

Main Features:

- 5 position mechanical safety lock system;
- Dual cylinders and scissor lift design for maximum strength and stability;
- Portable trolley supports pump and moves lift;
- Easily adjustable sliding radius arms;
- Automatic mechanical release by novel trip-over mechanism at the highest position.



Scissor lift is designed and built to lift all kinds of vehicles, all other use are unauthorized. In particular, the lift is not suitable for washing spray work. And not lift the vehicle whose weight exceeds the maximum weight.

2. SPECIFICATIONS

Main Technical Parameter:

Model No.	8030P
Capacity	3000kg
Max. Lifting Height	1200mm
Max. Lifting Height with adaptors	1350mm
Min. Height	110mm
Overall Length	1740mm
Overall Width	1880mm
Lifting Time	≤35s
Lowering Time	≤25s
Power Supply	AC 400V or 230V±5% 50/60Hz
Power	2.2kw
Hydraulic Oil	12L wearable hydraulic oil
Working Temperature	5-40°C
Working Humidity	30-95%
Noise Level	< 76db
Installation Altitude	Height above sea level ≤1000M
Storage Temperature	-25°C~55°C

Motor

Type.....Y90L
 Max. Power..... 2.2kw
 Max. Voltage.....AC 400 or 230V ±5%
 Max Electricity..... 400V:5A
230V:10A
 Max Frequency50/60Hz
 Poles..... 4
 Speed.....1450 r.p.m./min.
 Building Shape..... B14
 Insulation Class.....F

When connecting the motor refer to the enclosed diagrams, and the motor direction is clockwise.

Pump

Type.....P4.3
 Model.....Gear Pump
 Max. Flux.....4.3cc/r

Joint Type.....Joint Overfull Valve
 Continuous Working Pressure.....210bar
 Intermittent Working Pressure.....150~300bar
Inject 15 liters of wearable hydraulic oil into the oil tank.

Also the personnel safety zone must be defined in relation to vehicle with unusual dimensions.



Read this chapter carefully and completely since important information for the safety of the operator or others in case of improper use of the lift is included.

Lift Dimension Picture:

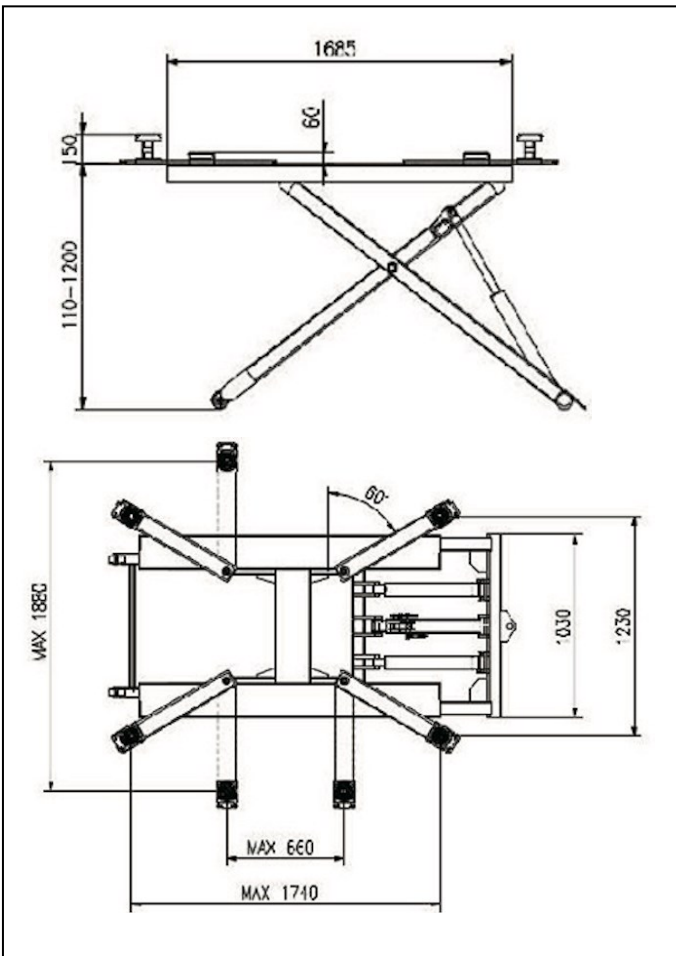

Fig. 2 Lift Dimension

TYPES OF VEHICLES SUITABLE FOR:

This lift are suitable for virtually all vehicles with total weight not exceed than 3000Kg



THE LOWER PARTS OF THE VEHICLE UNDERBODY COULD INTERFERE WITH STRUCTURAL PARTS OF THE LIFT, TAKE PARTICULAR PARTS OF THE SPORTS-CAR.

The lift will also handle customized or non-standard vehicles provided they are within the maximum specified carrying capacity.



Lifts are designed and built to lift vehicles and hold them in the elevated position in an enclosed workshop. All other uses of the lifts are unauthorized. In particular, the lifts are not suitable for:

- Washing spray work;
- Creating raised platforms for personnel or lifting personnel;
- Use as a press for crushing purposes;
- Use as elevator;
- Use as a lift jack for lifting vehicle bodies or changing wheels.



The manufacturer is not liable for any injury to persons or damage to vehicles and other property caused by the incorrect and unauthorized use of the lifts.

During lifting and descent, the operator must remain in the control station as the diagrams illustrated.

As the diagrams illustrated: The presence of persons inside the danger zone indicated is strictly prohibited. During operations persons are admitted to the area beneath the vehicle only when the vehicle is already in the elevated position, when the platforms are stationary, and when the mechanical safety devices are firmly engaged (e.g.: the safety gear is completely locked).

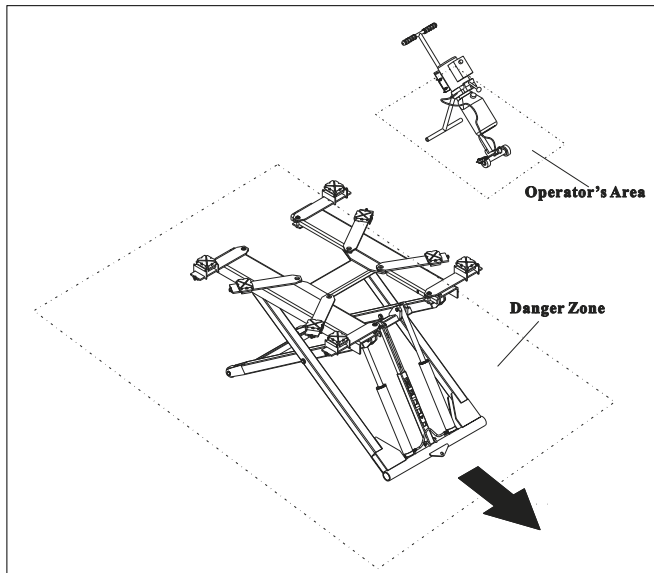

Fig. 3



DO NOT USE THE LIFT WITHOUT PROTECTION DEVICES OR WITH THE PROTECTION DEVICES INHIBITED.

FAILURE TO COMPLY WITH THESE REGULATION CAN CAUSE SERIOUS INJURY TO PERSONS, AND IRREPAIRABLE DAMAGE TO THE LIFT AND THE VEHICLE BEIN LIFED.

GENERAL PRECAUTIONS



The operator and the maintenance fitter are required to observe the prescriptions of safety regulation in force in the country of installation of the lift.

Furthermore, the operator and maintenance fitter must:

- Always work in the stations specified and illustrated in this manual;
- Never remove or deactivate the guards and mechanical, electrical, or other types of safety devices;
- Read the safety notices placed on the machine and the safety information in this manual.

3. SAFETIES

In the manual all safety notices are shown as follows:



WARNING: indicates following operations that are unsafe and can cause minor injury to persons and damage the lift, the vehicle or other property.



CAUTION: indicates possible danger that can result in serious injury to people and damage property.



RISK OF ELECTRIC SHOCK: a specific safety notice placed on the lift in areas where the risk of electric shock is particularly high.

RISK AND PROTECTION DEVICES

We shall now examine the risks that operators or maintenance fitters may be exposed to when the vehicle is standing on the platforms in the raised position, together with the various safety and protection devices adopted by the manufacturer to reduce all such hazards to the minimum.

For optimal personal safety and safety of vehicles, observe the following regulations:

- Do not enter the danger zone when vehicles are being lifted. *(Fig. 3)*
- Make sure the vehicle is positioned correctly. *(Fig. 4)*

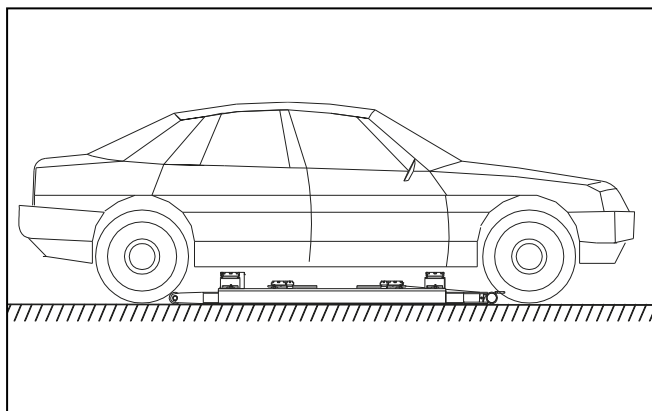

Fig. 4

- Be sure to lift only approved vehicles, never exceed the specified carrying capacity, maximum height, and projection (vehicle length and width);
- Make sure that there are no person on the platforms during up and down movements and during standing.

GENERAL RISKS FOR LIFTING OR DESCENT:

The following safety equipments is used to protect over loading or the possibility of engine failure.

In the condition of over loading, the over-falling valve will open and directly return oil to the oil tank. *(Fig. 5)*

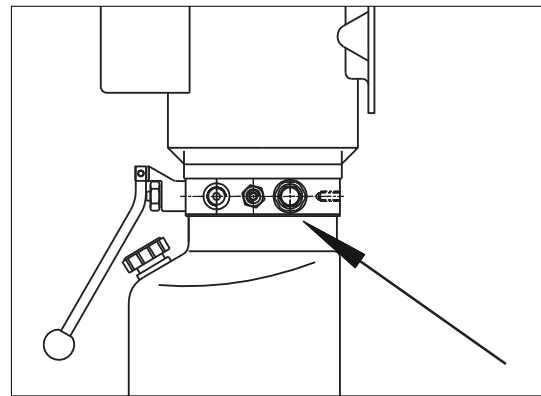

Fig. 5 Over-falling Valve

Each bottom of oil cylinder is equipped with antiknock and locked valve. When the oil pipe is burst in the circuit of hydraulic pressure, the relevant antiknock and locked valve will work and limit the speediness of platform. *(Fig. 6)*



Fig. 6

Safety tooth and gear module are parts which guarantee the safety of personnel beneath the machine in failure condition of other protections. So make sure the integrity of gear module and that the safety tooth has occluded completely. *(Fig. 7)*

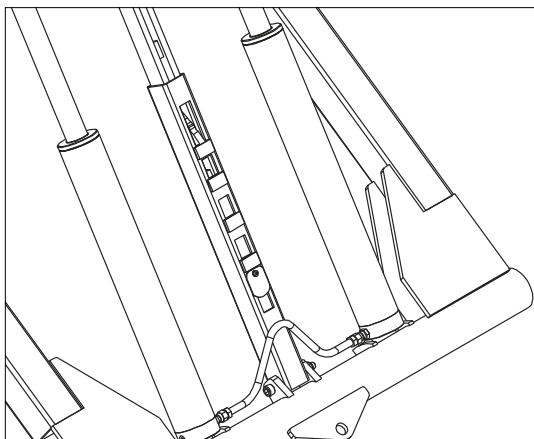

Fig. 7



There is nothing abnormal should be left on the safety modules to prevent safety gear from occlude normally.



RISKS FOR PERSONNEL

This heading illustrates potential risks for the operator, maintenance fitter, or any other person present in the area around the lift, result from incorrect use of the lift.



RISKS FOR EXTRUSION

During up and down operations, personnel leave the said area without following the rule and instruction.

During up and down operations, no person is admitted to work beneath the movable parts of the lift, should work in the safe zone. (Fig. 3)



RISK OF IMPACT

Before the operator begins up and down movements, make sure that there are no personnel inside the danger zone. When, due to operational reasons, the lift is stopped at relatively low elevations, personnel must be careful to avoid impact with parts of the machine not marked with special colors.

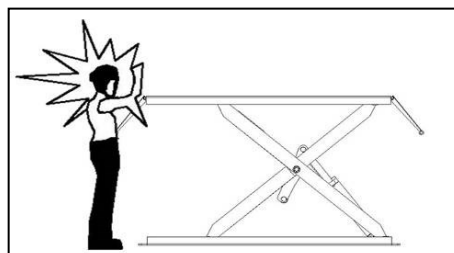

Fig. 8 Risk of Impact



RISK OF FALLING OFF (PERSONNEL)

During up and down operations, personnel are prohibited from entering the platforms and the vehicle to avoid falling off.



RISK OF FALLING (VEHICLE)

This hazard may arise in the case of incorrect positioning of the vehicle on the platforms, overweight of the vehicle, or in the case of vehicles of dimensions that are not compatible with the capacity of the lift.

When the platform is being tested, the vehicle engine can not be turned on.

There is nothing should be placed on the lift-lowering area and the movable parts of the lift.



RISK OF SLIPPING

Caused by lubricant contamination of the floor around the lift. The area beneath and immediately surrounding the lift and also the platforms must be kept clean. Remove any oil spills immediately.

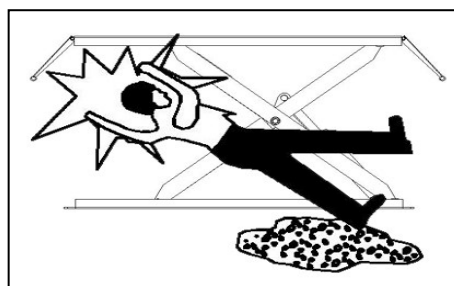

Fig. 9 Risk of Slipping



RISK OF ELECTRIC SHOCK

Risk of electric shock in areas of insulated and shattered electric equipments.

Do not use jets of water, steam solvents or paint next to the lift, and take special care to keep such substances clear of the electrical control panel.



RISKS RELATED TO INAPPROPRIATE LIGHTING

The operator and the maintenance fitter must be able to assure that all the areas of the lift are properly and uniformly illuminate compliance with the laws in force in the place of installation.

During up and down operations, the operator should continually observe the lift and can operate it only in the position of operator. When lifting and lowering the vehicle, the cushion needs being put in the bottom of chassis.



The handling of safety devices is strictly forbidden. Never exceed the maximum carrying capacity of the lift, make sure the vehicles to be lifted have no load.



It is therefore essential to adhere scrupulously to all regulations regarding use, maintenance and safety contained in this manual.

4. INSTALLATION AND DEBUGGING



SKILLED AND AUTHORIZED PERSONNEL ONLY SHOULD BE ALLOWED TO PERFORM THESE OPERATIONS, FOLLOW ALL INSTRUCTIONS SHOWN BELOW CAREFULLY, IN ORDER TO PREVENT POSSIBLE DAMAGE TO THE CAR LIFT OR RISK OF INJURY TO PEOPLE.

4.1 INSTALLATION

4.1.1 POWER UNIT INSTALLATION

Fix the power pack on the trolley with bolts supplied.

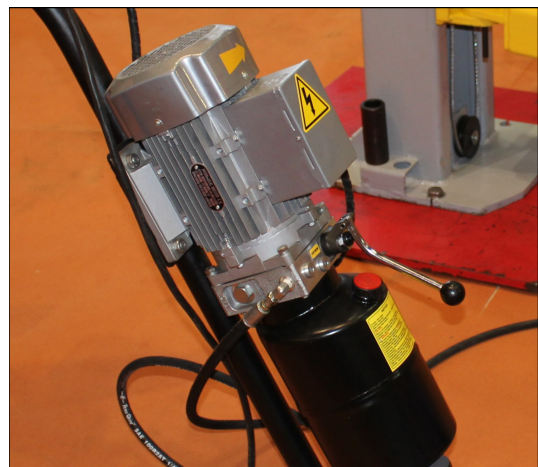

Fig. 10

4.1.2 OIL HOSE CONNECTION

Connect the oil hose from the main machine to the gear pump and make sure the bolts are fastened.



Fig. 11

4.1.3 ELECTRICAL CONNECTION



Only skilled special person is allowed to perform the operations.

4.1.3.1 Single phase motor

Connect one four-core 2.5mm² power cable to the junction box of the power unit. Make sure that the machine is securely grounded.

4.1.3.2 Three phase motor

Connect one three-core 2.5mm² power cable to the junction box of the power unit. Make sure that the machine is securely grounded.

4.1.4 ARM INSTALLATION

Fix the four arms on the platform with bolts supplied. Then put the brackets and rubber pads on the arms as *Fig. 12* shows.



Fig. 12

4.1.5 FILL THE OIL TANK

Open the cap of the oil tank. Fill the oil tank with 46# wearable hydraulic oil until it reaches the oil level indicator. After debugging, fill in the tank again until it reaches the oil level.



Note: do not fill in different types of hydraulic oil.

4.2 DEBUGGING

- Clean the surroundings of the machine. Make sure that there is no debris on the moving parts of the machine.
- Connect the power cable of the power unit to the power supply.
- Press the lift button. Check if the machine is lifted up. (if the machine is with 3-phase motor and the lift does not go up, change the connection of any two of the three live lines.)
- If the machine goes up, keep pressing the lift button until the cylinder reaches its travel. Then keep pressing the lowering lever until it reaches the floor. Continue this operation 3~5 times to excavate the air inside the cylinders until the lift goes up smoothly.

5. OPERATIONS



Only skilled and having been trained personnel is allowed to perform the operations. Check proceedings as following.

5.1 OPERATION NOTICE

- Clear obstacles around the lift before operation.
- During lifting or lowering, no person is allowed to stand neat the two sides and beneath the machine, and no person is allowed on the two platform.
- Avoid lifting super heavy vehicles or other goods.
- When lifting vehicle, the chassis of the vehicle should be filled up with rubber cushion.
- When lowering vehicle, lift the platform a bit firstly, notice that whether two safety pawls and safety teeth have been disengaged completely. If not, stop lowering.
- When the equipment is not used for a long time or over night, the machine should be lowered to the lowest position on ground, and remove vehicle, and cut off power supply.

5.2 CHECK BEFORE OPERATION

- Check if the ground around the machine is clean.
- Check if the rotating parts moves flexibly. Otherwise, lubricate the corresponding parts.
- Check if the safety lock moves normally and smoothly. Otherwise clean and lubricate the lock.
- Check if there is any leakage on cylinders, oil hoses and oil fittings. If yes, repair or replace in time.
- Observe if there is any abnormal sound from the motor and gear pump.
- Check if the locking plate works normally. Otherwise clean and lubricate the part to make sure it works normally.,

5.3 OPERATION PROCEDURE

- Drive the car onto the lift.

- Stop the car when the center of gravity of car and lift are together. Apply the brake.

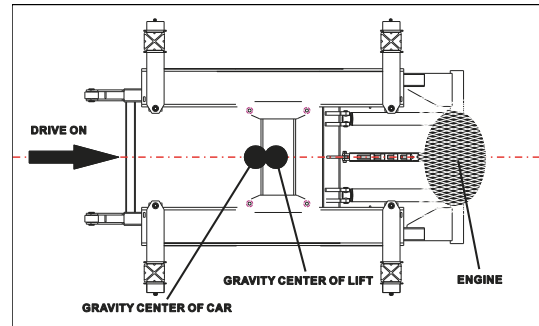

Fig. 13

- Observe and confirm the supporting point on the car chassis. Then put the rubber pads with suitable height on the supporting point.
- Press the lift button to make the rubber pads contact with the supporting point of the car until the car leave the ground slightly. Then stop lifting.
- Check if the car is on level and if the supporting point is appropriate.
- Continue pressing the lifting button until the automotive reaches the required height. Lock it on the position. *(Refer to 5.4 WORKING PRINCIPLE OF LOCKING MECHANISM)*



Warning: the locking device will trip over automatically when the lift reaches the highest position. The locking device is disengaged at this moment. Do not operate maintenance or service in case of personal injury or even death.

- During lifting, check if the locking plate works properly. Each locking comes with clear “click” sound. When the lift reaches each locking position, lower the lift a little bit to engage the locking.
- At this moment, maintenance worker can carry out the maintenance or repair.
- After finish the maintenance work, check if the area around/beneath the lift is clear of any obstacles. Then carry out the lowering operation.



Note: To disengage the locking, the machine must be lifted to the highest position. The locking plate will trip over automatically to the disengaged status. Before lifting operation, make sure that the lift is in the lowest position. Only at this moment, the locking plate is trip over to the ready-to-be-engaged status.

- Press the lifting button to lift the machine to the highest position to disengage the locking. Then press the lowering lever on the power unit to lower the machine to the lowest point.
- During lifting and lowering operation, make sure that there is no any potential safety hazards to human, automotives and machine.
- Do not carry out maintenance work or repair work during lifting or lowering process. Generally speaking, the maintenance work is allowed when the locking plate is slightly higher than the locking position. After finishing lifting operation, make sure that the control switch is cut off. And put the power unit in safe area in case it injure personnel.



Warning: only authorized workers are allowed to enter the working area.

5.4 WORKING PRINCIPLE OF LOCKING MECHANISM

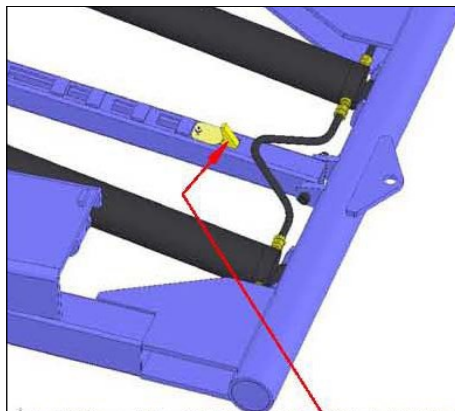

Fig. 14

- When the lift lowers to the lowest position, the locking plate will trip over automatically.

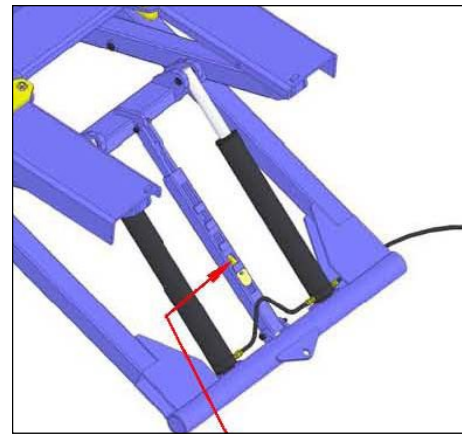

Fig. 15

- When the lift reaches the first locking position, lower the lift a little bit to engage the lock.

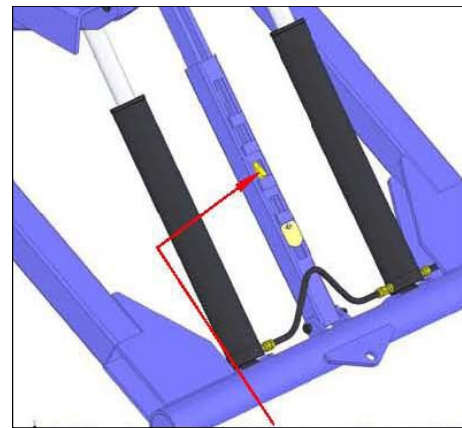

Fig. 16

- When the lift reaches the second locking position, lower the lift a little bit to engage the lock.

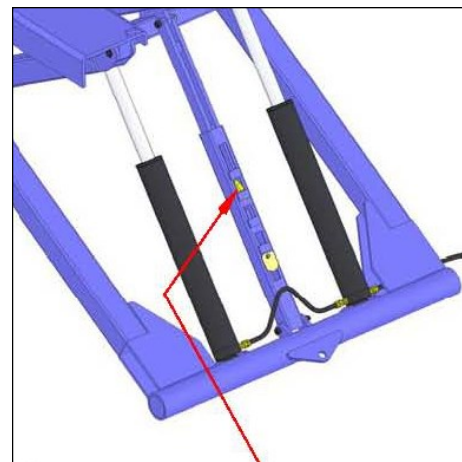

Fig. 17

- When the lift reaches the third locking position, lower the lift a little bit to engage the lock.

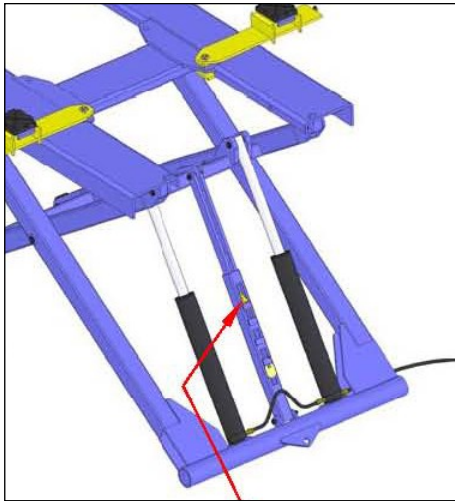

Fig. 18

- When the lift reaches the forth locking position, lower the lift a little bit to engage the lock.

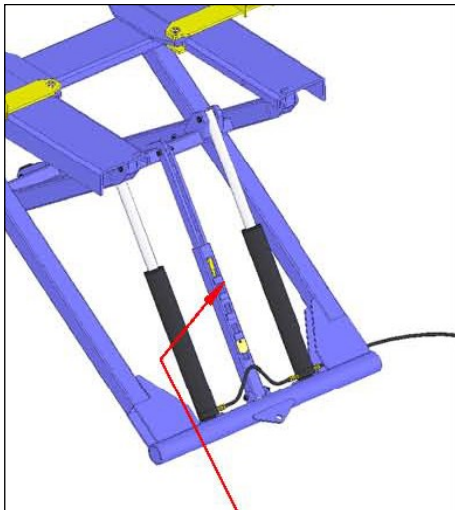

Fig. 19

- When the lift reaches the highest position, the locking plate trips over automatically. At this moment, the lift can be lowered to the lowest position.

6. MAINTENANCE AND CARE



Skilled personnel only is allowed to perform the operations.

- All bearings and hinges on this machine must be lubricated once a week by using an oiler.
- Make sure that the locking mechanism works properly in case of accident.
- Make sure that there is no oil leakage on cylinders, oil hoses and oil fittings.
- Make sure that there is no abnormal sound from gear pump and motor.
- Make sure that the lifting button and the lowering lever is normal.
- The hydraulic oil must be replaced every two months. The oil level should always be kept at upper limit position.



The machine should be lower to the lowest position when replace hydraulic oil, then let the old oil out, and should be filter the hydraulic oil.

7. TROUBLE SHOOTING GUIDE

7.1 PUMP MOTOR DOES NOT RUN:

- a) Breaker tripped or fuse blown. Check breaker and incoming power.
- b) Motor thermal overload tripped. Wait for overload to cool.
- c) Defective control switch, check switch.
- d) Faulty wiring connections, check wiring diagram.

7.2 PUMP MOTOR RUNS BUT WILL NOT RAISE OR HOLD A LOAD:

- a) A foreign object under check valve. Push handle down and push switch and or remove check valve. Clean the ball and seat and replace the nut.
- b) Oil level low, check oil reservoir.

7.3 LIFT MAKES GROANING OR POPPING NOISES:

- a) Dry hinges and/or cylinder pins. Lubricate with grease.

7.4 PUMP MOTOR RUNS BUT THE LIFT PICKS UP PARTIAL LOAD ONLY:

- a) Relief valve setting is too low. Reset pressure relief valve.
- b) Hydraulic seals damaged (call factory for instructions) See step #2b.

7.5 OIL BLOWS OUT BREATHER:

- a) Oil reservoir overfilled.
- b) Lift lowered too quickly while under heavy load.

7.6 LIFT MAKES GROANING SOUND WHEN RAISING OR LOWERING:

- a) Bleed cylinder manually. Trapped air can cause groaning
- b) Add an ounce of oil to the air side of the piston at the breather on the top of the cylinder.

EXPLOSIVE DRAWING

Mid-Rise Lift
KT-L-M7

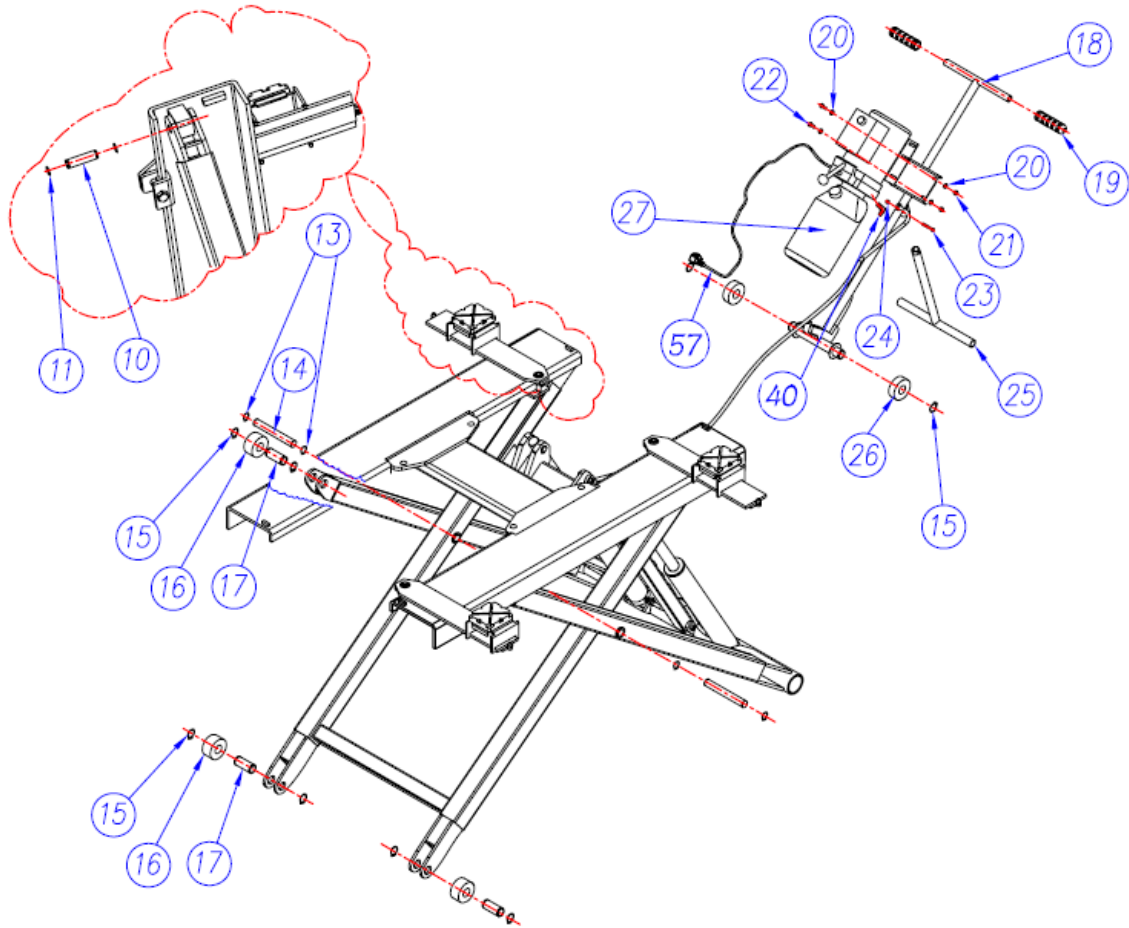
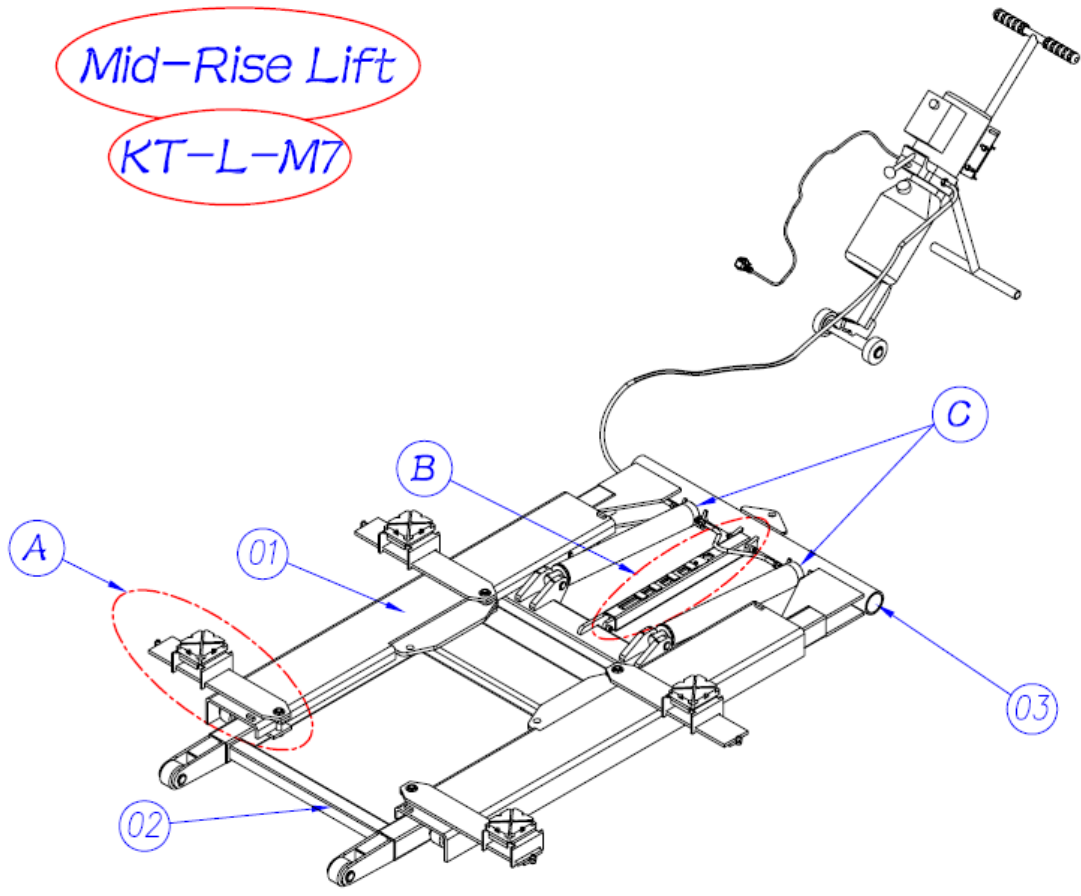

2 OF 2

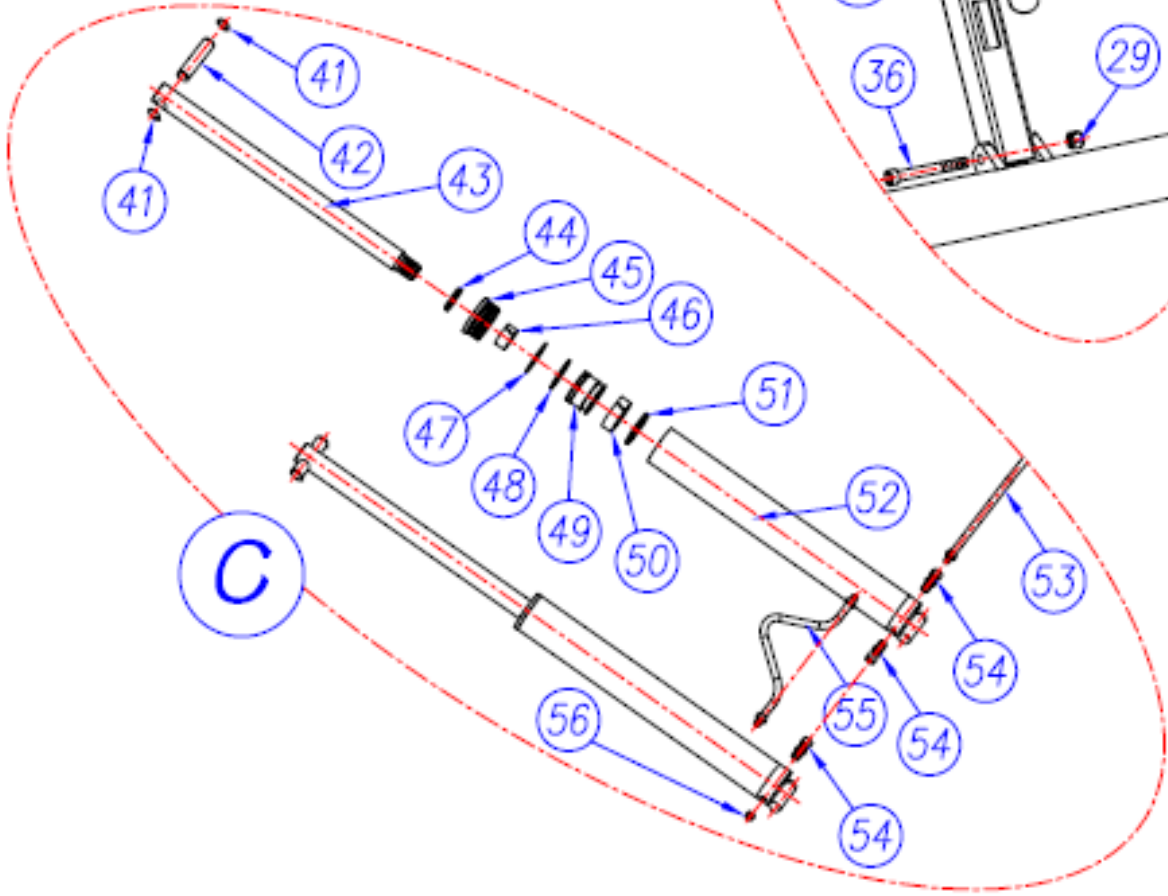
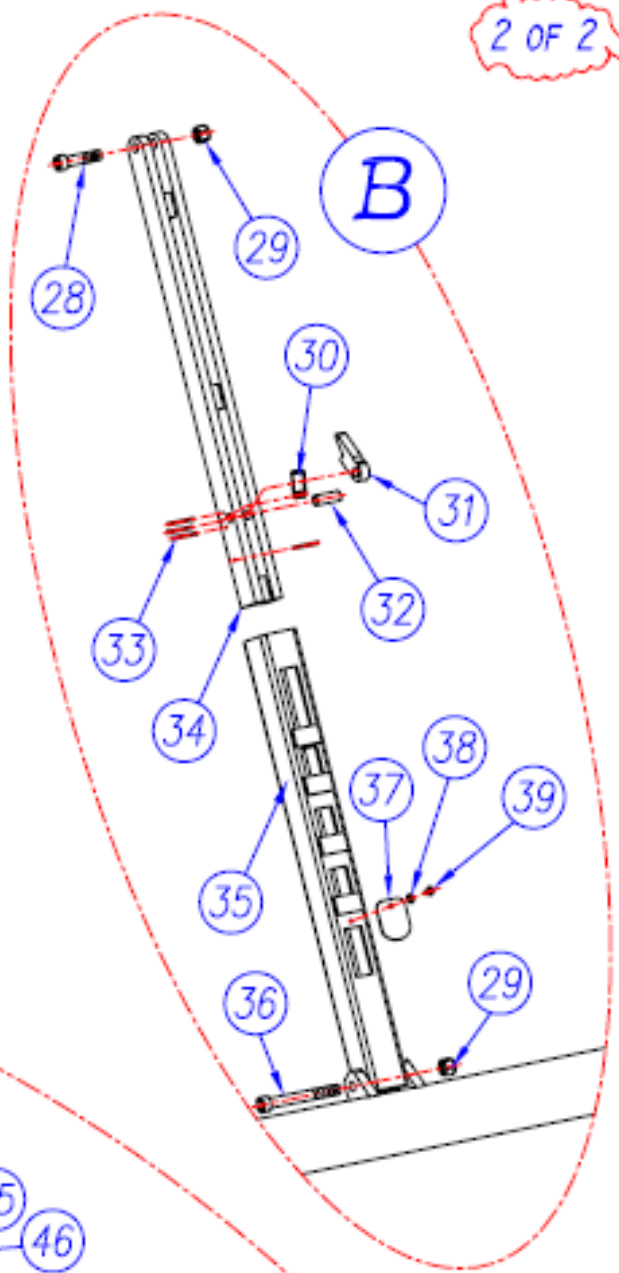
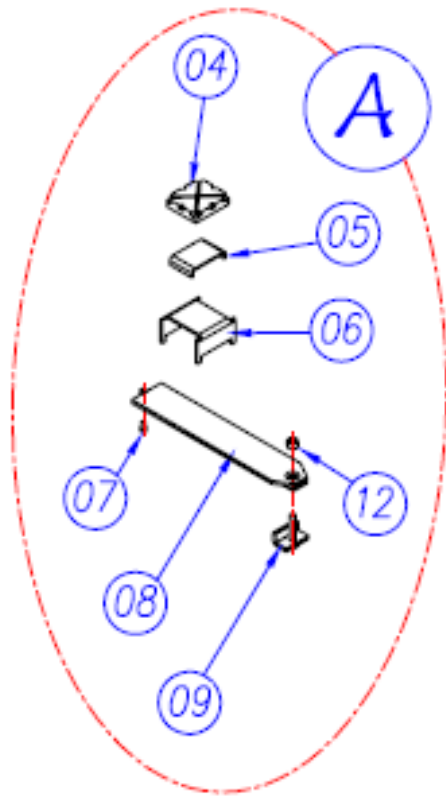

PARTS LIST

S/N	PARTS NAME	QUANTITY
01	PLATFORM ASSEMBLY	1
02	MOVING ARM ASSEMBLY	1
03	FIXED ARM ASSEMBLY	1
04	RUBBER PAD	4
05	SUPPORTING PLATE	4
06	SUPPORTING BRACKET	4
07	INNER HEXGON NUT	4
08	LIFTING ARM	1
09	FIXING PLATE	4
10	FIXING PIVOT	2
11	SNAP SPRING	4
12	LOCK NUT	4
13	SNAP SPRING	4
14	ROTATING SHAFT	2
15	SNAP SPRING	12
16	ROLLER	4
17	ROLLER SHAFT	4
18	TROLLEY ASSEMBLY	1
19	HANDLE SLEEVE	2
20	FLAT WASHER	8
21	BOLT	4
22	OUTER HEXGON BOLT	4
23	OUTER HEXGON BUT	1
24	LOCK NUT	1
25	SUPPORT LEG	1
26	TROLLEY ROLLER	2
27	POWER UNIT	1
28	INNER HEXGON NUT	1
29	LOCK NUT	2
30	TORSION SPRING	1

S/N	PARTS NAME	QUANTITY
31	LOCKING PLATE	1
32	CYLINDRICAL PIN	1
33	ELASTICAL CYLINDRICAL PIN	4
34	INNER SUPPORTING BAR	1
35	LOCKING BAR	1
36	INNER HEXGON NUT	1
37	RUBBER WASHER	1
38	WASHER	1
39	CROSS TYPE SUNK SCREW	1
40	OIL HOSE FITTING	1
41	CIRCLIP	4
42	CYLINDER FIXING SHAFT	2
43	PISTON ROD	2
44	DUST-PROOF SEALING KIT	2
45	CYLINDER COVER	2
46	GUIDING TAPE	2
47	O-RING STOPPER	2
48	O-RING	2
49	PISTON	2
50	GUIDING TAPE	2
51	PISTON SEALING KIT	2
52	CYLINDER BARREL	2
53	LONG OIL HOSE	1
54	HOSE FITTING	3
55	SHORT OIL HOSE	1
56	PLUG	1
57	POWER CABLE	1

WARRANTY

The structural components on the electro-hydraulic scissor lift are warranted for three years on equipment. Operating components are warranted one year to the original purchaser, to be free of defects in material and workmanship.

The manufacturer shall repair or replace at their option for this period those parts returned to the factory freight prepaid which prove after inspection to be defective.

This warranty only applies to the original purchaser of the equipment. This warranty does not extend to defects caused by ordinary wear, abuse, misuse, shipping damage, or damage as the result of improper maintenance.

This warranty is exclusive and in lieu of all other warranties expressed or implied.

In no event shall the manufacturer be liable for special, consequential or incidental damages for the breach or delay in performance of the warranty.

The manufacturer reserves the right to make design changes or add improvements to its product line without incurring any obligation to make such changes on product sold previously.