

**Version: L-2050B SS190505.01**

**Serial No.:** \_\_\_\_\_

**Production Date:** \_\_\_\_\_

# **USER'S MANUAL**

## **ELECTRO-HYDRAULIC TWO-POST LIFT**

**MODEL: L-2050B**



## TABLE OF CONTENTS

<b>1. Safety</b> .....	<b>1</b>
<b>1.1 Introduction</b> .....	<b>1</b>
<b>1.2 Symbols</b> .....	<b>1</b>
<b>1.3 Hazard and Forbidden Operation Warnings</b> .....	<b>1</b>
<b>1.4 Manual Keeping</b> .....	<b>2</b>
<b>1.5 Intended Use</b> .....	<b>2</b>
<b>1.6 Safety Instructions for Commissioning</b> .....	<b>2</b>
<b>1.7 Safety Instructions for Operation</b> .....	<b>2</b>
<b>1.8 Safety Instructions for Servicing</b> .....	<b>3</b>
<b>1.9 Safety Features</b> .....	<b>3</b>
<b>1.9.1 Dead Man's Type Control</b> .....	<b>3</b>
<b>1.9.2 Equalizing System</b> .....	<b>3</b>
<b>1.9.3 Collision Prevention Switch</b> .....	<b>3</b>
<b>1.9.4 Automatic Arm Restraint</b> .....	<b>3</b>
<b>1.9.5 Pressure Relief Valve</b> .....	<b>3</b>
<b>2. Specifications</b> .....	<b>3</b>
<b>3. Installation</b> .....	<b>5</b>
<b>3.1 Important Concrete and Anchoring Information</b> .....	<b>5</b>
<b>3.2 Anchoring Tip Sheet</b> .....	<b>5</b>
<b>3.3 Installation Procedure</b> .....	<b>6</b>
<b>4. Test and checks to perform before start-up</b> .....	<b>7</b>
<b>5. Operation</b> .....	<b>8</b>
<b>5.1 Preparations</b> .....	<b>8</b>
<b>5.2 Raising</b> .....	<b>8</b>
<b>5.3 Locking</b> .....	<b>9</b>
<b>5.4 Lowering</b> .....	<b>9</b>
<b>6. Maintenance</b> .....	<b>10</b>
<b>6.1 Daily Pre-operation Check (8 Hours)</b> .....	<b>10</b>
<b>6.2 Weekly Maintenance (40 Hours)</b> .....	<b>10</b>

<b>6.3 Yearly Maintenance.....</b>	<b>10</b>
<b>7. Troubleshooting .....</b>	<b>11</b>
<b>Appendix A Hose Connection Diagram .....</b>	<b>13</b>
<b>Appendix B Hydraulic Oil Hose Connection Diagram .....</b>	<b>14</b>
<b>Warranty.....</b>	<b>15</b>

# 1. SAFETY

## 1.1 Introduction

Thoroughly read this manual before operating the lift and comply with the instructions.

Personal injury and property damage incurred due to non-compliance with these safety instructions are not covered by the product liability regulations.

## 1.2 Symbols



*Failure to comply with instructions could result in personal injury.*



*Failure to comply with instructions could result in property damage.*



*Important information*

## 1.3 Hazard and Forbidden Operation WARNINGS

### ● WARNING



Clear area if vehicle is in danger of falling.



Position vehicle with center of gravity midway between adapters.



Remain clear of lift when raising or lowering vehicle.



Avoid excessive rocking of vehicle while on lift



Do not override self-closing lift controls.

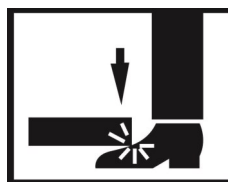

Keep feet clear of lift while lowering.

### ● CAUTION



Lift to be used by trained operator only.



Authorized personnel only in lift area.

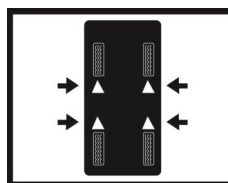

Use vehicle manufacturer's lift points.

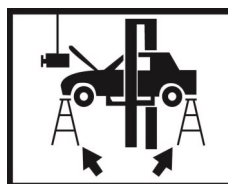

Always use safety stands when removing or installing heavy components.

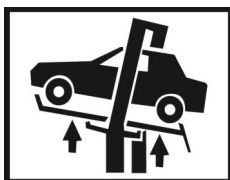

Auxiliary adapters may reduce load capacity.



Use height extenders when necessary to ensure good contact.

● SAFETY INSTRUCTION



Read operating and safety manuals before using lift.

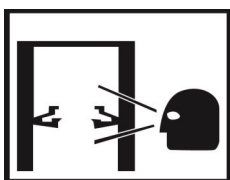

Proper maintenance and inspection is necessary for safe operation.

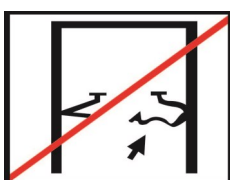

Do not operate a damaged lift.

The company is not liable for possible problems, damage, accidents, etc. resulting from failure to follow the instructions contained in this manual.

Only skilled technicians of AUTHORISED DEALERS or SERVICE CENTRES AUTHORISED by the manufacturer shall be allowed to carry out lifting, transport, assembling, installation, adjustment, calibration, settings, extraordinary maintenance, repairs, overhauling and dismantling of the lift.

**THE MANUFACTURER IS NOT RESPONSIBLE FOR POSSIBLE DAMAGE TO PEOPLE, VEHICLES OR OBJECTS IF SAID OPERATIONS ARE CARRIED OUT BY UNAUTHORIZED PERSONNEL OR THE LIFT IS IMPROPERLY USED.**

Any use of the machine made by operators who are not familiar with the instructions and procedures contained herein shall be forbidden.

**1.4 MANUAL KEEPING**

For a proper use of this manual, the following is recommended:

- Keep the manual near the lift, in an easily accessible place.
- Keep the manual in an area protected from the damp.
- Use this manual properly without damaging it.
- Any use of the machine made by operators who are not familiar with the instructions and procedures contained herein shall be forbidden.

This manual is an integral part of lift: it shall be given to the new owner if and when the lift is resold.

**1.5 Intended Use**

The lift is designed for the safe lifting of automotive vehicles. Observe the rated load capacity and load distribution of the lift.

Model No.	Load Capacity	Load Distribution Front	
		Minimum	Maximum
L-2050B	5000 kg	2 : 3	3 : 2

In principle, the lift is designed for both approach directions.

For a long service life, we recommend to use the short support arms for engaging the engine side of the vehicle.

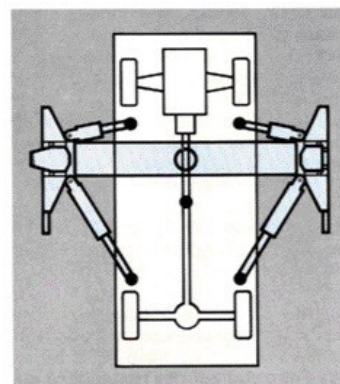

**1.6 Safety Instructions for Commissioning**

- The lift may be installed and commissioned by authorized service personnel only.
- The standard lift version may not be installed and commissioned in the vicinity of explosives or flammable liquids, outdoors or in moist rooms (e.g. car wash).

**1.7 Safety Instructions for Operation**

- Read the operating manual.
- Lift operation by authorized personnel over 18 years only.

- Always keep the lift and lift area clean and free of tools, parts, debris etc.
- Once the disk adapters contact the lift points, check arm restraints for engagement.
- After raising the vehicle briefly, stop and check the disk adapters for secure contact.
- Always lift the vehicle using all four adapters.
- Make sure the vehicle doors are closed during raising and lowering cycles.
- Closely watch the vehicle and the lift during raising and lowering cycles.
- Do not allow anyone to stay in lift area during raising and lowering cycles.
- Do not allow anyone on lift or inside raised vehicle.
- Only use the lift for its intended purpose.
- Comply with the applicable accident prevention regulations.
- Do not overload the lift. The rated load capacity is indicated on the lift nameplate.
- Only use the vehicle manufacturer's recommended lift points.
- After positioning the vehicle apply the parking brake.
- Use caution when removing or installing heavy components (center-of-gravity displacement).
- The main switch serves as emergency switch. In case of emergency turn to position 0.
- Protect all parts of the electrical equipment from humidity and moisture.
- Protect the lift against unauthorized usage by padlocking the main switch.

### 1.8 Safety Instructions for Servicing

- Maintenance or repair work by authorized service personnel only.
- Turn off and padlock the main switch before doing any maintenance, or repair work.
- Work on pulse generators or proximity switches by authorized service personnel only.

- Work on the electrical equipment by certified electricians only.
- Ensure that ecologically harmful substances are disposed of only in accordance with the appropriate regulations.
- Do not use high pressure/steam jet cleaners or caustic cleaning agents. Risk of damage!
- Do not replace or override the safety devices.

## 1.9 Safety Features

### 1.9.1 Dead Man's Type Control

The operator is required to hold the controls in the engaged position to raise or lower the lift.

### 1.9.2 Equalizing System

The lift is provided with equalizing cables to ensure level movement of both carriages.

### 1.9.3 Collision Prevention Switch

A rope-operated limit switch prevents collisions between vehicle roof and cross member.

To lower the arms completely, release the "Lower" button and press the "Lower to bottom position" button. Lift travel to the lower limit stop is accompanied by an audible signal.

### 1.9.4 Automatic Arm Restraint

Once the lift is raised, the arm restraints are locked automatically to avoid any swivel under load.

### 1.9.5 Pressure Relief Valve

A pressure relief valve is used to limit the hydraulic working pressure to a maximum of 150 bar.

## 2. SPECIFICATIONS

*See following pages.*



*The properties indicated apply to lifts running at operating temperature.*

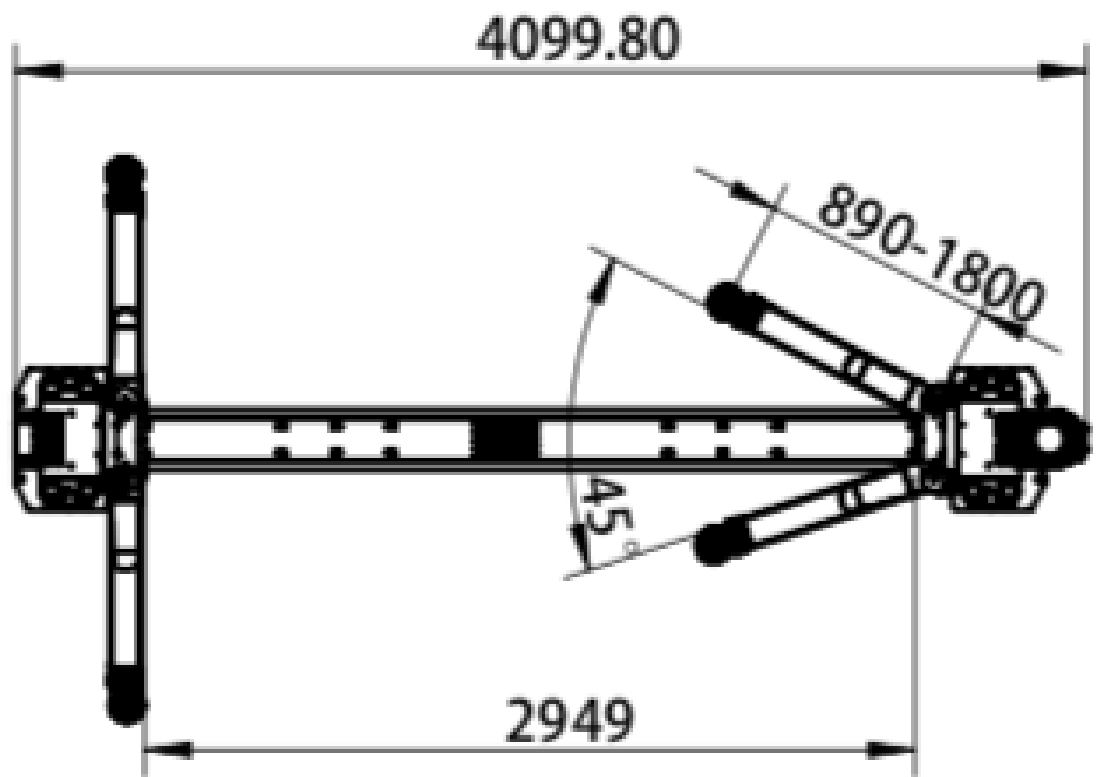
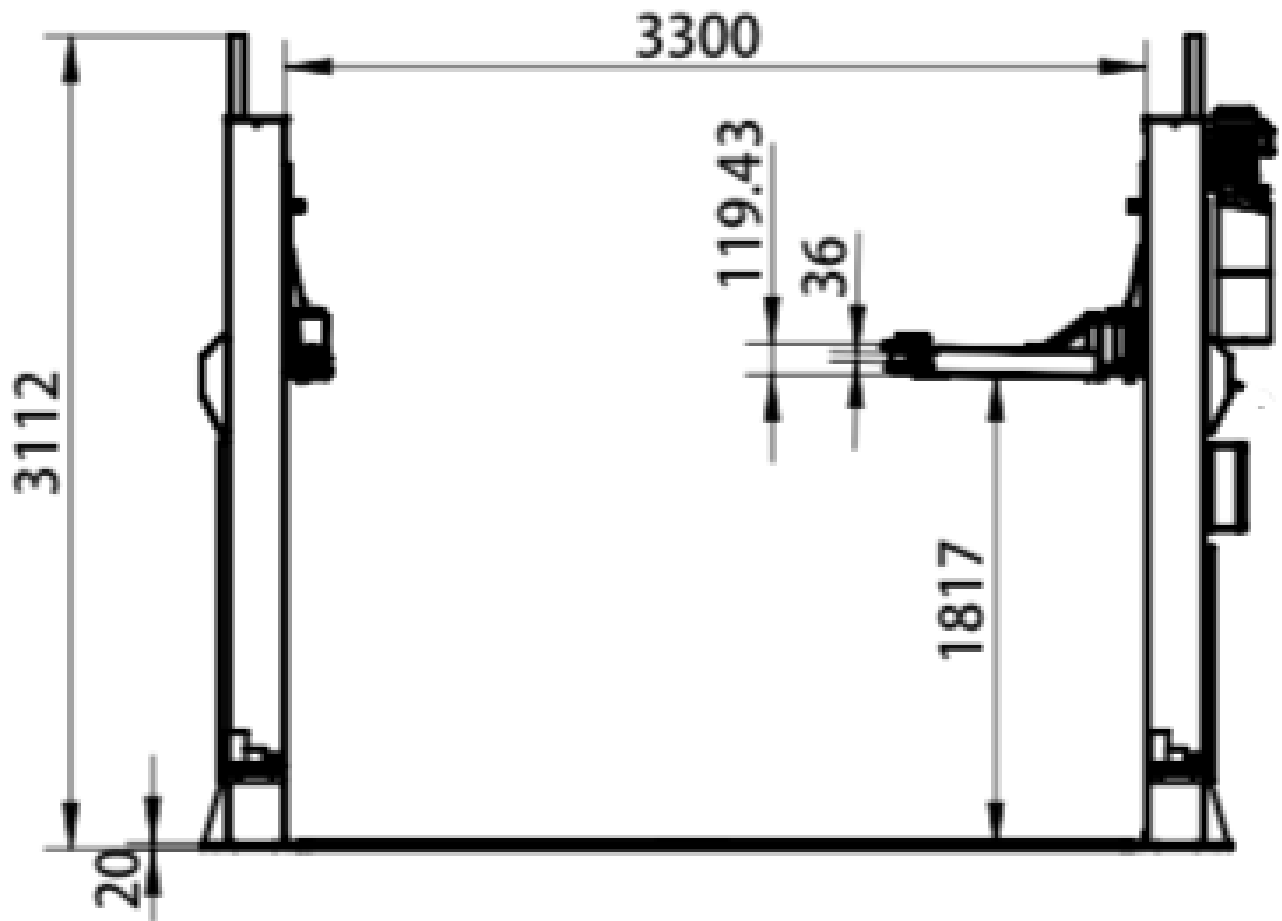



Model No.	L-2050B
Capacity	5000 kg
Rise	1800 mm
Rise with extensions	1920 mm
Overall Height	3112 mm
Overall Width	4099 mm
Drive Through Clearance	2949 mm
Width inside Column	3300 mm
Front Arm Reach	890-1800 mm
Rear Arm Reach	890-1800 mm
Voltage	220V/380V , 50HZ/60HZ , 1PH/3PH
Motor	2.2KW



*Specifications are subject to change without notice.*



*Check for ceiling clearance first to confirm the lift can be set up in your bay.*

### 3. INSTALLATION

#### 3.1 IMPORTANT CONCRETE AND ANCHORING INFORMATION

●Concrete shall have compression strength of at least 3,000 PSI and a minimum thickness of 4"(102mm) in order to achieve a minimum anchor embedment of 3-1/4"(83mm). When using the standard supplied 3/4"(19mm) x 5-1/2"(140mm)long anchors, if the top of the anchor exceeds 2-1/4"(57mm) above the floor grade, you DO NOT have enough embedment.



**CAUTION: DO NOT Install on asphalt or other similar unstable surface. Columns are supported only by anchoring in floor.**

#### 3.2 INSTALLATION PRECEDURE



**PLEASE READ THIS INSTRUCTION BEFORE STARTING TO OPERATE THE LIFT.**

**STEP 1:** After unloading the lift, place it near the intended installation location. Remove the shipping bands and packing materials from the unit. Remove the packing brackets and bolts holding the two columns together. (Do not discard bolts, they are used in the assembly of the lift.) Once the power unit column location is decided, insure that the proper lift placement is observed from walls and obstacles. Also check the ceiling height for clearance in this location. Note the power unit column can be located on either side. It is helpful to try and locate the power side with the passenger side of the vehicle when loaded on the lift to save steps during operation.

**STEP 2:** Install the top plate of both column.

**STEP 3:** Raise the columns to a vertical position.

**STEP 4:** Position the columns facing each other 3420 mm outside base plates.

**STEP 5:** Use the existing holes in column base plate as a guide for drilling the 3/4"(19.2mm) diameter holes into the concrete. Maintain a 6"(150mm) minimum distance from any slab edge or seam. Hole to hole spacing should be a minimum 6-1/2"(165mm) in any direction. Concrete thickness or hole depth should be a minimum of 4"(102mm).

## ANCHORING TIP SHEET

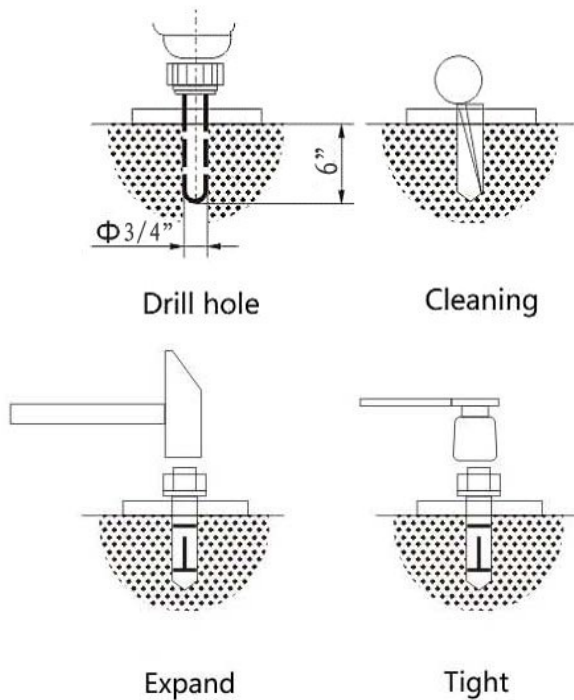

- Anchors must be at least 6" (152mm) from the edge of the slab or any seam.
- Use a concrete hammer drill with a carbide tip, solid drill bit the same diameter as the anchor, 3/4" (19.2mm). Do not use excessively worn bits or bits which have been incorrectly sharpened.
- Keep the drill in a perpendicular line while drilling. Let the drill do the work. Do not apply excessive pressure. Lift the drill up and down occasionally to remove residue to reduce binding.
- Drill the hole to depth equal to the length of anchor.
- For better holding power blow dust from the hole.
- Place a flat washer and hex nut over threaded end of anchor, leaving approximately 1/2 (13mm) inch of thread exposed carefully tap anchor. Do not damage threads. Tap anchor into the concrete until nut and flat washer are against base plate. Do not use an impact wrench to tighten. Tighten the nut, two or three turns on average concrete (28-day cure). If the concrete is very hard only one or two turns may be required. Check each anchor bolt with torque wrench set to 120 foot pounds.



Only specialized technicians are allowed to DILL HOLE. Need to wear the appropriate protective equipment.

**STEP 6:** Using a level, check column for side-to-side plumb and front-to-back plumb. Use 3/4" ( $\Phi 20$ mm). washers or shim stock, placing shims as close as possible to the hole locations. This will prevent bending the column bottom plates. Tighten 3/4" (M20mm). anchor bolts to 150-lbs.

**STEP 7, 8:** Installing the equalizing cables. Set carriages on the first safety latch engagement. Be sure each carriage is at the same height by measuring from the top of the base to the bottom of the carriage (double check the latches before working under the carriages). This dimension should be within 3/8". Run first cable. Tighten nut on one cable stud. Pull the other end of cable and run nut on it. Tighten both nuts. Repeat above for second cable.

**STEP 9:** Install the swing arms on the carriages. Check for proper engagement of the arm lock. The rack on the lock should fully engage the gear on the arm.

**STEP 10,11,12:** Install the safety latch on both side columns. Connect the safety release cable between two latches. Check that the tension of the cable is tight. Pull the single point release handle several times and check the tension again by making sure both latches release at the same time when the handle is pulled.

**STEP 13:** Mount the power unit on lift.

**STEP 14,15:** Connecting the hydraulic hoses.

**STEP 16:** Mount the floor plate.

**STEP 17:** Connect the limit switch to the power unit.

**STEP 18:** Mount the cover of the safety latch.

### 3.3 Adjustment

**STEP 1:** Adjust the carriage cables tension. Adjust each cable to approximately 1/2" side-to-side play. Check the latch releases to insure the carriage is still sitting on the appropriate latch.

**STEP 2:** Remove the vent plug from the power unit and fill the reservoir. Use a Ten Weight (SAE-10) non-foaming, non-detergent hydraulic fluid (Texaco HD46 or equal). The unit will hold twelve quarts of fluid.

**STEP 3:** Make the Electrical hookup to the power unit.

**Warning:** *the wiring must comply with local code. Have a certified electrician make the electrical hook-up to the power unit. Protect each circuit with time delay fuse or circuit breaker.*

**STEP 4:** Do not place any vehicle on the lift at this time. Cycle the lift up and down several times to insure latches engage properly and all air is removed from the system. To lower the lift, first raised the lift to clear the latches and then pull down the safety release handle to lower lift. If latches function out of sync, tighten the cable on the latch that engages first.



**NOTE:** *The cable stud that connects to the front right corner of the carriage should be connected first by pulling the stud through the carriage hole and up where it is easy to be held by locking pliers. Pull the stud back into place after threading at least 1/2" of the stud past the locknut. Connect the other ends to the rear right corners of the carriage with at least 1/2" of thread showing past the lock nut (cables run on the inside of the carriage). It may be necessary to manually raise both carriages above the cylinder to provide enough space to use the locking pliers. Make sure the carriage is set in the LOCK position.*

## 4. TESTING AND CHECKS TO PERFORM BEFORE START-UP

### 4.1 MECHANIAL TESTS

- Attachment and tightness of bolts, fittings and connections
- Free sliding of moving parts
- Clean state of various parts of the machine
- Position of the protection device
- Arms blocking device

### 4.2 ELECTRIC TESTS

- Machine earth connections

### 4.3 OPERATING OF THE FOLLOWING DEVICES

- Rise limit switch
- Manual lowering valve

### 4.4 HYDRAULIC OIL TEST

- Sufficient oil in the tank
- No leaks
- Cylinder operation

**NOTE:** *If oil is not present, fill the reservoir of the power unit with the necessary amount of oil.*

### 4.5 ROTATION DIRECTION TEST

The motor should turn in the direction of the arrow located on the power unit pump; check using brief start-ups (each start-up must last a maximum of two seconds). If problems arise in the hydraulic oil plant, see the "Troubleshooting" table in Chapter 7.



### 4.6 SET UP

#### WARNING

**THESE OPERATIONS MUST ALWAYS BE PERFORMED BY TECHNICIONS OF THE AUTORIZ SERVICE CENTRE INDICATED IN THE FRONT OF THIS MANUAL.**

#### 4.6.1 NO-LOAD TESTS

In this phase check the following:

- That the up, down and lowering lever operate correctly;
- That the rack reaches the maximum height;
- That there are no abnormal vibrations in the posts and in the arms;
- That the safety wedges enter the iron pads under the carriage;
- That the rise limit switches trip;
- After having done all as previously recommended, the height difference between the arms of the two carriages, is less than 1cm. On the contrary, adjust their level by working on the counter nuts on the synchronous steel cables.

## 5. OPERATION



*Lift operation by authorized personnel over 18 years only.*

*Apply the parking brake after positioning the vehicle on the lift.*

*Do not allow anyone to stay in lift area during raising and lowering cycles. Closely watch the vehicle and the lift during raising and lowering cycles.*

*Observe the rated load capacity and load distribution. Do not allow anyone to climb on lift or stay inside vehicle.*

*After raising the vehicle briefly, stop and check adapters for secure contact.*

*Once the disk adapters contact the lift points, check arm restraints for engagement. Make sure the vehicle doors are closed during raising and lowering cycles.*

*In case of defects or malfunctions such as jerky lift movement or deformation of the superstructure, support or lower the lift immediately. Turn off and padlock the main switch. Contact qualified service personnel.*

### 5.1 Preparations

Each support arm is provided with an automatic arm restraint which unlatches automatically when the lift is in bottom position.

When the carriages are in a raised position, the arm restraint can be disengaged by pulling the release pin.

- Fully lower the lift and swing the arms to full drive-through position.
- Slowly position vehicle midway between adapters. Apply the parking brake.
- Swing and telescope arms as required to position adapters under vehicle manufacturer's recommended lift points.
- Turn the disk adapters that they evenly contact all four lift points.



*Once the disk adapters contact the lift points, check arm restraints for engagement. If necessary, slightly move the arms until the gear segments mesh.*

*Never unlatch the arm restraints when the lift is under load.*

- Leave vehicle and remain clear of lift.



*Always lift the vehicle using all four adapters.*

### 5.2 Raising



*During raising and lowering cycles: Closely watch the vehicle and the lift, do not allow anyone to stay in lift area and make sure the vehicle doors are closed.*

*Once the disk adapters contact the lift points, check arm restraints for engagement. After raising the vehicle briefly, stop and check adapters for secure contact.*

- Slowly position vehicle midway between adapters. Apply the parking brake.
- Swing and telescope arms as required to position adapters under vehicle manufacturer's recommended lift points.
- Turn the disk adapters that they evenly contact all four lift points. Once the disk adapters contact the lift points, check arm restraints for engagement. If necessary, slightly move the arms until the gear segments mesh. Never unlatch the arm restraints when the lift is under load.
- Leave vehicle and remain clear of lift. Always lift the vehicle using all four adapters.
- Avoid rocking of vehicle.
- Keep lift free of tools, parts, etc.
- Fasten the vehicle to the support arms using lashing straps when removing or installing heavy components.

- Avoid rocking of vehicle.
- Keep lift free of tools, parts, etc.
- Fasten the vehicle to the support arms using lashing straps when removing or installing heavy components.

### 5.2.1 Raising

During raising and lowering cycles: Closely watch the vehicle and the lift, do not allow anyone to stay in lift area and make sure the vehicle doors are closed.



*Once the disk adapters contact the lift points, check arm restraints for engagement. After raising the vehicle briefly, stop and check adapters for secure contact.*

- Press the Up button on control box. Lift stops once switch is released or upward travel limit is reached. When vehicle is in raised position: Observe all accident prevention regulations.
- Do not allow unauthorized persons to stay under the raised vehicle.

### 5.3 Lowering

*During raising and lowering cycles: Closely watch the vehicle and the lift, do not allow anyone to stay in lift area and make sure the vehicle doors are closed.*

● Before lowering the carriages, the safety wedges must be disconnected. Press the Up push button that the carriage will be lift about 3-cm, then press the Down button to releases the safety wedges and activates the down electro-valve. Lowering speed is regulated by the “flow regulating valve” in the pump. Lowering stops when the hydraulic cylinders are completely unloaded. When the carriages are totally lowered, the automatic arm -blocking device opens and lets the carriages rotate.



Warning: Always make sure safety latches on both sides clear the rack at same time when pulling down the release handle by adjusting the cable.

## 6. MAINTENANCE SCHEDULE

The following periodic maintenance is the suggested minimum requirements and minimum intervals; accumulated hours or monthly period, which ever comes

sooner. If you hear a noise or see any indication of impending failure- cease operation immediately- inspect, correct and/or replace parts as required.



**WARNING-USERS SHOULD ALWAYS INSPECT LIFTING EQUIPMENT AT THE START OF EVERY SHIFT. THESE AND OTHER PERIODIC INSPECTIONS ARE THE RESPONSIBILITY OF THE USER.**



### 6.1 DAILY PRE-OPERATION CHECK (8 HOURS)



*The user should perform daily check. ATTENTION! LOOK OUT! Daily check of safety latch system is very important - the discovery of device failure before needed could save you from expensive property damage, lost production time, serious personal" injury and even death.*



● Check safety lock audibly and visually while in operation.

● Check safety latches for free movement and full engagement with rack.

● Check hydraulic connections, and hoses for leakage.

● Check chain connections - bends, cracks-and looseness.

● Check snap rings at all rollers and sheaves.

● Check bolts, nuts, and screws and tighten.

● Check wiring & switches for damage.

● Keep base plate free of dirt, grease or any other corrosive substances.

● Check floor for stress cracks near anchor bolts.

● Check swing arm restraints.

### 6.2 WEEKLY MAINTENANCE (40 HOURS)

● Check anchor bolts torque to 150 ft-lbs for the 3/4" (M20) anchor bolts.



**Do not use impact wrench.**

- Check floor for stress cracks near anchor bolts.
- Check hydraulic oil level.
- Check and tighten bolts and nuts, and screws.
- Check cylinder puller assembly for free movement or excessive wear on cylinder yoke or pulley pin.
- Check cable pulley for free movement and excessive wear.

### 6.3 YEARLY MAINTENANCE

- Lubricate chain.
- Grease rub blocks and column surface contacting rub blocks.
- Change the hydraulic fluid, good maintenance procedure makes it mandatory to keep hydraulic fluid clean. No hard fast rules can be established; operating temperature, type of service, contamination levels, filtration, and chemical composition of fluid should be considered. If operating in dusty environment shorter interval may be required.



*The following items should only be performed by a trained maintenance expert.*

- Replace hydraulic hoses.
- Replace chains and rollers.
- Replace cables and sheaves.
- Replace or rebuild air and hydraulic cylinders as required.
- Replace or rebuild pumps / motors as required.
- Check hydraulic and air cylinder rod and rod end (threads) for deformation or damage.
- Check cylinder mount for looseness and damage.

Relocating or changing components may cause problems.

Each component in the system must be compatible; an undersized or restricted line will cause a drop in pressure. All valve, pump, and hose connections should be sealed and/or capped until just prior to use. Air hoses can be used to clean fittings and other components. However, the air supply must be filtered and dry to prevent contamination. Most important - cleanliness -

contamination is the most frequent cause of malfunction or failure of hydraulic equipment.

## 7. TROUBLE SHOOTING

See the following page.



Trouble	Cause and Pheonomena	Resolutions
Motor does not run.	Breaker or fuse blown	Call electrician.
	Motor thermal overload tripped	Wait for overload to cool.
	Faulty wiring connections	Call electrician.
	Defective up button	Call electrician for checking.
Motor runs but does not rise.	A piece of trash is under check valve	Push handle down and push the up button at the same time. Hold for 10-15 seconds. This should flush the system.
	The clearance between the plunger valve of the lowering handle is too small.	Check the clearance between the plunger valve of the lowering handle. There should be 1/16".
	Dirty on the ball and seat of check valve.	Remove the check valve cover and clean ball and seat.
	Oil level too low.	Oil level should be just under the vent cap port when the lift is down!!
Oil blows out breather of power unit:	Lift lowered too quickly while under a heavy load.	Remove excessive weight from lift.
	Oil reservoir overfilled.	Reduce the oil to the oil level.
Motor hums and does not run.	Impeller fan cover is dented.	Take off and straighten.
	Faulty wiring	Call electrician..
	Bad capacitor	Call electrician.
	Low voltage	Call electrician.
	Lift overloaded	Remove excessive weight from lift.
Lift jerks going up and down.	Air in hydraulic system	Raise lift all the way to top and return to floor; Repeat 4-6 times. Do not let this overheat power unit.
Oil leaks	Oil leaks around the tank-mounting flange. Oil reservoir overfilled.	Check the oil level in the tank. The level should be two inches below the flange of the tank. Check with a screwdriver.
	Oil leaks around the rod end of the cylinder. The rod seal of the cylinder is out.	Rebuild or replace the cylinder.
	Oil leaks around the breather end of the cylinder. The piston seal of the cylinder is out.	Rebuild or replace the cylinder.
Lift makes excessive noise.	Leg of the lift is dry and requires grease.	Grease the legs.
	Cylinder pulley assembly or cable pulley assembly is not moving freely.	Grease the pulley assembly.
	May have excessive wear on pins or cylinder yoke.	Replace the pins or clinder yoke.

## APPENDIX A HOSE CONNECTION DIAGRAM

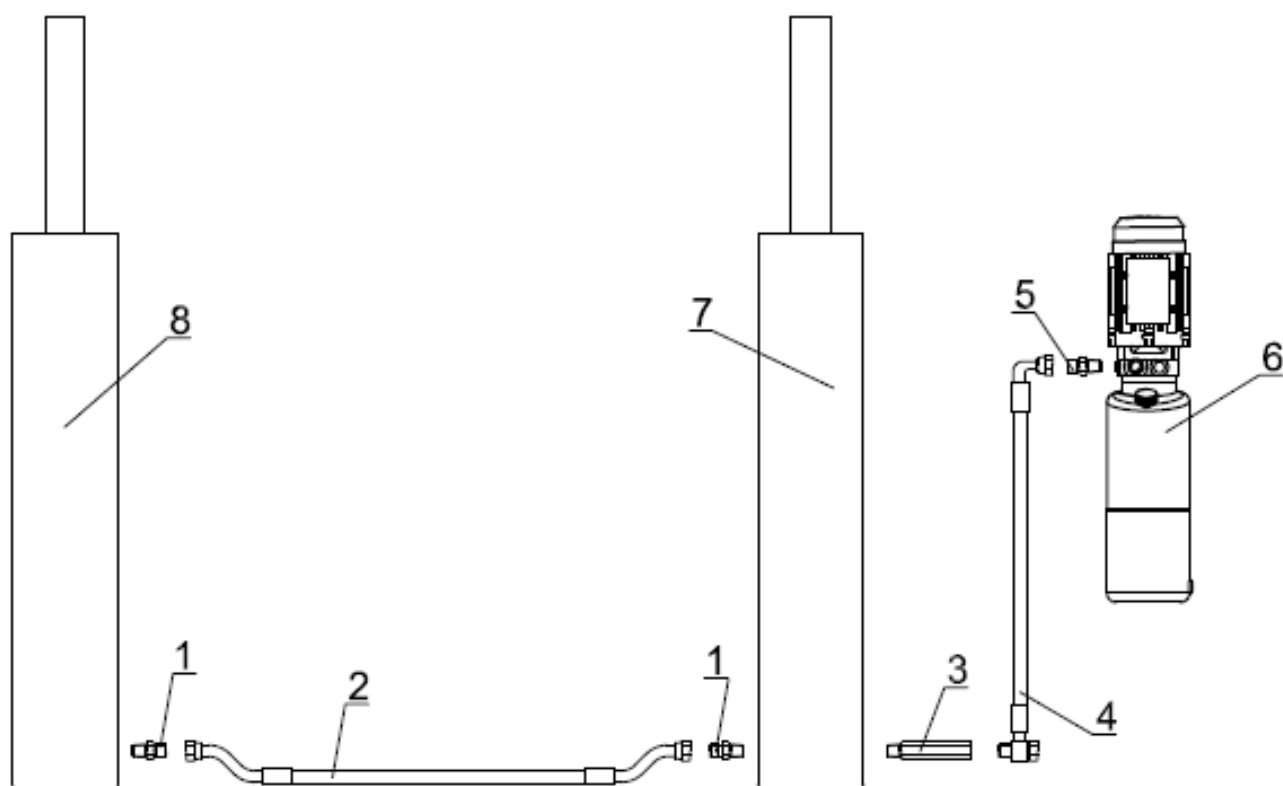

1. Joint G1/4 - M16x1.5
2. 2965mm High pressure oil pipe M16x1.5
3. 100mm Joint G1/4 - M16x1.5
4. 1100mm High pressure oil pipe QM14x1.5 - M16x1.5
5. Joint M14x1.5 - M16x1.5
6. Power unit
7. Main oil cylinder
8. Sub oil cylinder



**APPENDIX B**  
**HYDRAULIC OIL HOSE CONNECTION DIAGRAM**

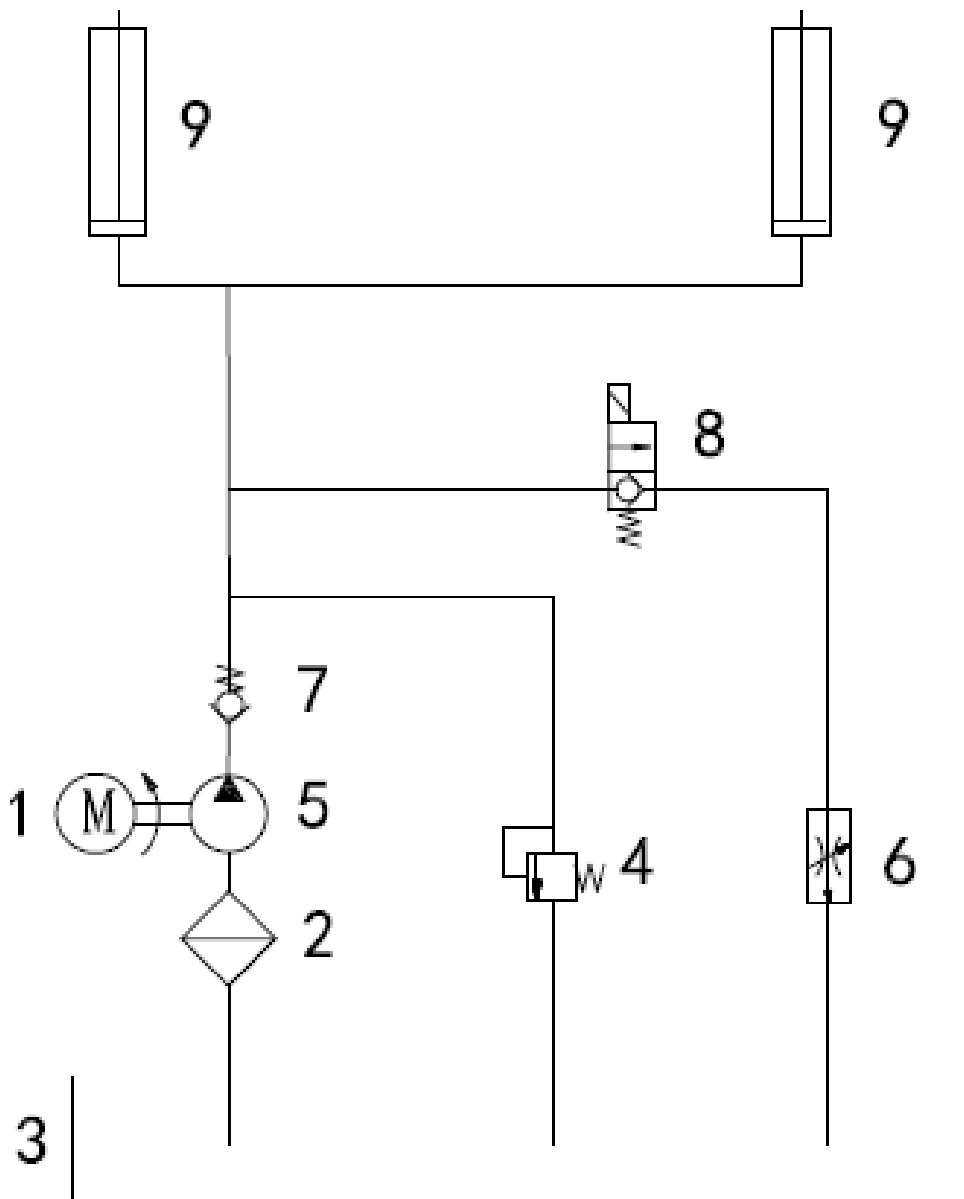

S/N	DESCRIPTION
1	Motor
2	Filter
3	Tank
4	Pressure relief valve
5	Pump
6	Flow control valve
7	Check valve
8	Directional valve
9	Operating Cylinder

## WARRANTY

**The structural components on your new automotive lift are warranted for three years on equipment. Operating components are warranted one year to the original purchaser, to be free of defects in material and workmanship.**

**The manufacturer shall repair or replace at their option for this period those parts returned to the factory freight prepaid which prove after inspection to be defective.**

**This warranty only applies to the original purchaser of the equipment. This warranty does not extend to defects caused by ordinary wear, abuse, misuse, shipping damage, or damage as the result of improper maintenance.**

**This warranty is exclusive and in lieu of all other warranties expressed or implied.**

**In no event shall the manufacturer be liable for special, consequential or incidental damages for the breach or delay in performance of the warranty.**

**The manufacturer reserves the right to make design changes or add improvements to its product line without incurring any obligation to make such changes on product sold previously.**

