

Version: 440

Serial No.: _____

Production Date: _____

USER'S MANUAL

ELECTRO-HYDRAULIC TWO-POST LIFT

MODEL: L-2040S SE

TABLE OF CONTENTS

Chapter 1 DESCRIPTION OF THE MACHINE	1
1.1 FIXED STRUCTURE.....	1
1.2 MOVING UNITS.....	1
1.3 LIFTING UNITS.....	2
1.4 HYDRAULIC POWER UNIT.....	2
1.5 CONTROL BOX	2
1.6 SAFETY DEVICES.....	2
Chapter 2 TECHNICAL SPECIFICATIONS	3
2.1 OVERALL DIMENSIONS	3
2.2 ELECTRIC MOTOR	3
2.3 HYDRAULIC UNIT PUMP	3
2.4 OIL	3
2.5 HYDRAULIC OIL HOSE CONNECTION DIAGRAM.....	3
2.6 VEHICLE WEIGHT AND SIZE.....	4
2.7 MAXIMUM DIMENSIONS OF VEHICLES TO BE LIFTED.....	4
Chapter 3 SAFETY	5
3.1 GENERAL PRECAUTIONS.....	5
3.2 RISKS OF ELECTRIC SHOCK.....	5
3.3 RISKS AND PROTECTION DEVICE.....	6
3.4 LONGITUDINAL AND LATERAL MOVEMENT.....	6
3.5 RISKS WHILE THE VEHICLE IS BEING RAISED.....	6
3.6 RISKS OF PERSONS.....	7
3.7 SAFETY INSTRUCTIONS FOR SERVICING.....	10
Chapter 4 INSTALLATION	10
4.1 INSTALLATION REQUISITE CHECKLIST.....	10
4.2 LIGHTING	11
4.3 FLOOR.....	11
4.4 ASSEMBLING.....	11
4.5 TESTING AND CHECKS TO PERFORM BEFORE START-UP.....	14

4.6 SEP UP	14
Chapter 5 OPERATIONS AND USE.....	15
5.1 COMMANDS.....	15
5.2 OPERATING SEQUENCE.....	16
Chapter 6 MAINTENANCE.....	16
6.1 PRECAUTIONS	16
6.2 PERIODIC MAINTENANCE.....	17
6.3 PERIODIC LUBRICATION CHART.....	19
Chapter 7 TROUBLESHOOTING.....	19
7.1 TROUBLE SHOOTING GUIDE.....	19
7.2 POSSIBLE PROBLEMS AND SOLUTIONS.....	19
APPENDIX A SPECIAL NOTES.....	20
APPENDIX B HYDRAULIC OIL HOSE CONNECTION DIAGRAM.....	21
WARRANTY.....	22

Chapter 1 DESCRIPTION OF THE MACHINE

The electro-hydraulic 2-post lift is a fixed installation. This means that it is anchored to the ground and built for lifting and positioning automobiles and vans at a certain height off the ground.

The lift consists of the following main parts:

- ◆ Fixed structure (posts);
- ◆ Moving units (carriages + arms);
- ◆ Lifting units (hydraulic cylinders + power unit);
- ◆ Control box;
- ◆ Safety devices.

Fig. 1 illustrates the working areas reserved for use by operators around the lift.

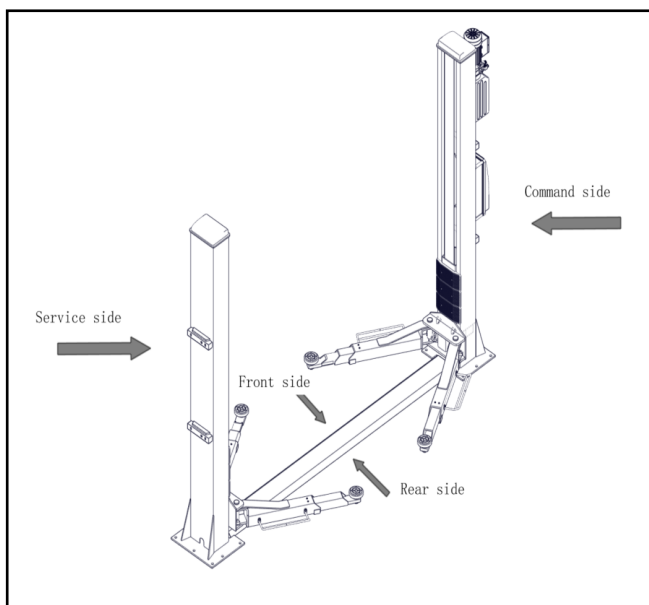

Fig. 1

- ◆ **Command side:** this side of the lift includes the area reserved for operators to access the control box.
- ◆ **Service side:** this is the opposite side of the command side.
- ◆ **Front side:** the side with the short arms.
- ◆ **Rear side:** the side with the long arms.

Fig. 2 illustrates the various parts of the lift.

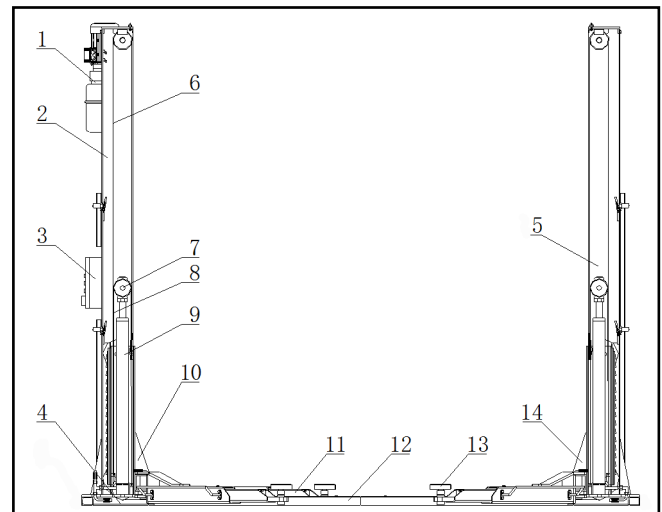

Fig. 2

1.1 FIXED STRUCTURE

The structure consists of:

- ◆ 2 posts, (service (**Fig. 2-5**) and command (**Fig. 2-2**) side post) built with bent steel plate. The base is welded to a drilled plate to be anchored to the floor. The electric control box (**Fig. 2-3**) and the hydraulic power unit (**Fig. 2-1**) are attached to the command post. Inside each post are the moving parts to lift the vehicles. The control panel and the hydraulic unit are fixed to the command post.
- ◆ The column set on the base which including fixed frame (**Fig. 2-4**) and cover plate (**Fig. 2-12**).

1.2 MOVING UNITS

Each unit consists of:

- ◆ Both carriage (**Fig. 2-10 and Fig. 2-14**) built with welded steel plate. It joints by chain (**Fig. 2-8**) and the cable (**Fig. 2-6**), and at the bottom to the lift arms by means of pins.
- ◆ The carriage moves along the post, guided by plastic sliding pads, located inside the post itself.
- ◆ Two telescopic arms, one long (**Fig. 2-11**) and one short (**Fig. 2-13**), built with tubular steel with a pad at each end that can be height adjusted to hold the car and on the opposite side the carriage connection hole.

1.3 LIFTING UNIT

It consists of:

- ◆ 2 hydraulic cylinders (*Fig. 2-7*), the carriages run by chains and synchronized by steel cables.
- ◆ 1 hydraulic unit (*Fig. 2-1*), on the command side, to set the cylinders run.

1.4 HYDRAULIC POWER UNIT

The hydraulic power unit consists of:

- ◆ An electric motor;
- ◆ A geared hydraulic pump;
- ◆ Descent hand-valve equipped with a manual oil drain valve; (*see the use and maintenance chapter*)
- ◆ A maximum pressure valve;
- ◆ Oil tank;
- ◆ An oil delivery and return flexible pipe to the cylinders feeding circuit.

Note: The oil delivery pipe may be under pressure.

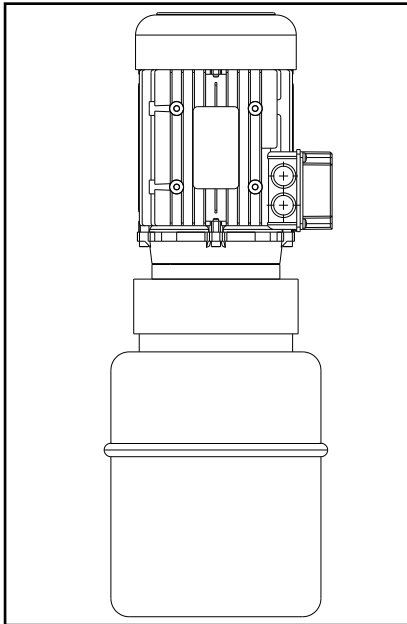

Fig. 3 Hydraulic Power Unit

1.5 CONTROL BOX

The panel that houses the electric control box contains the following:

- ◆ Main switch
- ◆ Up push button
- ◆ Down push button
- ◆ Lock push button

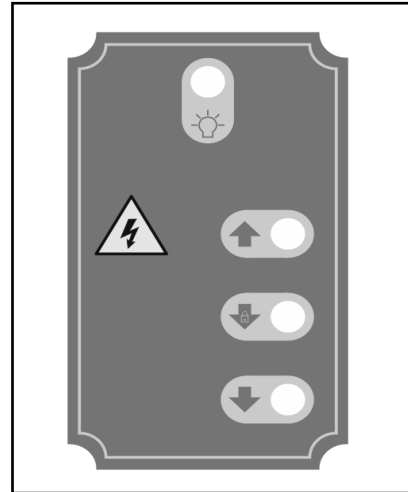

Fig. 4 Control Panel

1.6 SAFETY DEVICES

The safety devices include:

- ◆ Mechanical safety device for carriage;
- ◆ Arms locking system;
- ◆ 4 foot guards on the arms;
- ◆ A synchronous device to control the carriages movement;
- ◆ 2 post end limit switches;
- ◆ General electric safety devices;
- ◆ General hydraulic safety devices.

These safety devices will be described in further detail in the following chapters.

Chapter 2 TECHNICAL SPECIFICATIONS

2.1 OVERALL DIMENSIONS

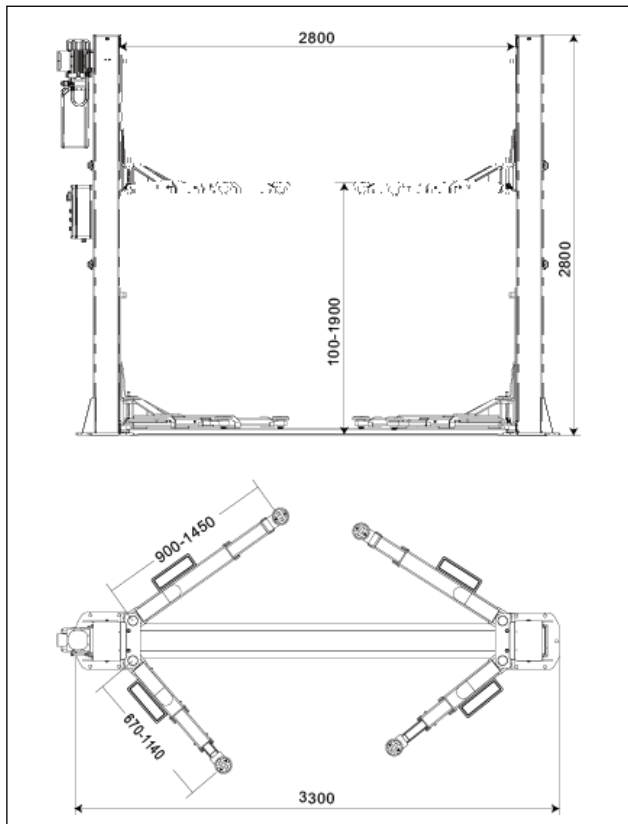

Fig. 5

Model No.	L-2040B
Capacity	4,000kg
Overall Height	2800mm
Overall Width	3300mm
Min. Height	100mm
Max. Lifting Height	1900mm
Width between Columns	2800mm
Long Arm Length	900-1400mm
Short Arm Length	670-1140mm
Lifting Time	≤60s
Lowering Time	≤40s

Table 1

2.2 ELECTRIC MOTOR

	Three-phase	Single phase
Power	2.2KW	1.8KW
Voltage	230-400V 3ph +/-5%	230V 1ph +/-5%
Frequency	50Hz	50Hz
Absorption	230V: 11A 400V: 6.4A	13A
N° of poles	4	
Speed	1400r.p.m.	1380r.p.m.
Construction	B14	
Insulation class	IP54	IP54
Type	90L4	90L4

Table 2

The motor must be connected with reference to the attached wiring diagrams.

The motor rotation direction must be the same as shown by the arrow on the pump: if not, modify the electrical connections. (see Chapter 4 INSTALLATION-ELECTRIC PLANT CONNECTION)

2.3 HYDRAULIC UNIT PUMP

	MOTOR	
	3Ph	1Ph
Type	R	T
Model	PHC	PHC
Size	7.8cm ³ /g	6.0cm ³ /g
Transmission: coupling type	E32	E32
Continuous operating pressure	160bar	150bar
Max. operating pressure (peak)	180bar	170bar

Table 3

2.4 OIL

The oil reservoir contains hydraulic mineral oil in accordance with ISO/DIN 6743/4 with a level of contamination that does not exceed class 18/15 according to ISO 4406, for example IP HYDRUS OIL 32, SHELL TELLUS OIL T32 or equivalent.

2.5 HYDRAULIC OIL HOSE CONNECTION DIAGRAM

See APPENDIX C HYDRAULIC OIL HOSE CONNECTION DIAGRAM.

2.6 VEHICLE WEIGHT AND SIZE

Lift rack can be adapted to virtually all vehicles no heavier than 4000kg, the dimensions of which do not exceed the following:

Max width: 2400mm

Max wheelbase: 3000mm

2.7 MAXIMUM DIMENSIONS OF VEHICLES TO BE LIFTED

The underbody of cars with low ground clearance may interfere with the structure of the lift. Pay particular attention in the case of low body sports cars.

Always keep the capacity of the lift in mind in the case of vehicles with particular characteristics.

THE SAFETY area will be determined by the dimensions of the vehicle.

The diagrams below include the criteria for defining the limits of use of the carrack.

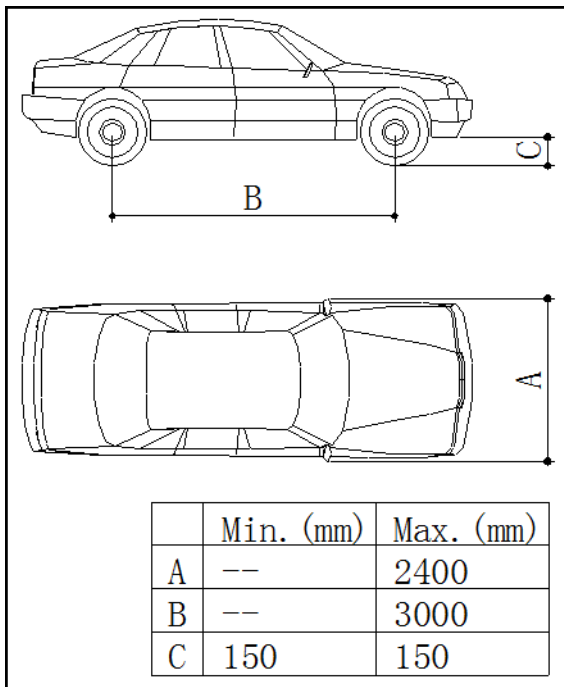

Fig. 6

CHECK MAXIMUM LOAD CAPACITY AND LOAD DISTRIBUTION IN CASE OF LARGER VEHICLES. MAXIMUM WEIGHT OF THE VEHICLE TO BE LIFTED SHOULD NOT BE:

L-2040B: Over 4,000kg

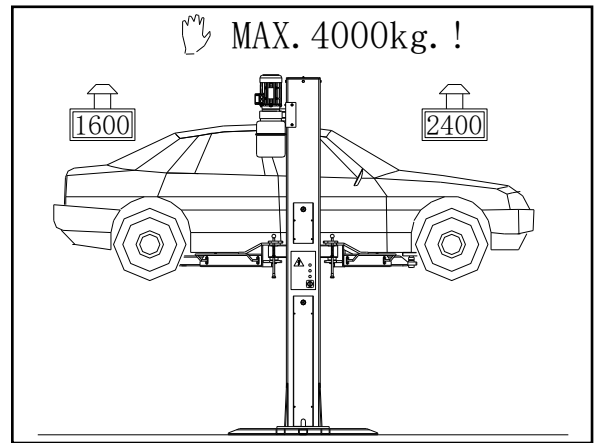

Fig. 7 Weight Distribution

Chapter 3 SAFETY

It is vital to read this chapter of the manual carefully and from beginning to end as it contains important information regarding the risks that the operator and the maintenance fitter may be exposed to in the eventuality that the lift is used incorrectly.

The following text contains clear explanations regarding certain situations of risk or danger that may arise during the operation or maintenance of the lift, the safety devices installed and the correct use of such systems, residual risks and operative procedures to use (general and specific precautions to eliminate potential hazards).

WARNING

Lift is designed and built to lift vehicles and hold them in the elevated position in a closed workshop. All other uses are unauthorized; in particular, the lift is not suitable for:

- ◆ Washing and respire work;
- ◆ Creating raised platforms or lifting personnel;
- ◆ Use as a makeshift press for crushing purpose;
- ◆ Use as goods lift
- ◆ Use as a jack for lifting vehicles or changing wheels.

THE MANUFACTURE DISCLAIMS ALL LIABILITY FOR INJURY TO PERSONS OR DAMAGE TO VEHICLES AND OTHER PCABLERTY CAUSED BY THE INCORRECT AND UNAUTHORISED USE OF THE LIFT.

During lift and descent movements, the operator must remain in the command station as defined in figure 8. The presence of persons inside the danger zone indicated in the same figure is strictly prohibited. The presence of persons beneath the vehicle during operations is permitted only when the vehicle is parked in the elevated position.

DO NOT USE THE LIFT WITHOUT PROTECTION DEVICES OR WITH THE PROTECTION DEVICES INHIBITED. FAILURE TO COMPLY WITH THESE REGULATIONS CAN CAUSE SERIOUS INJURY TO PERSONS, AND IRREPERABLE DAMAGE TO THE LIFT AND THE VEHICLE BEING LIFTED.

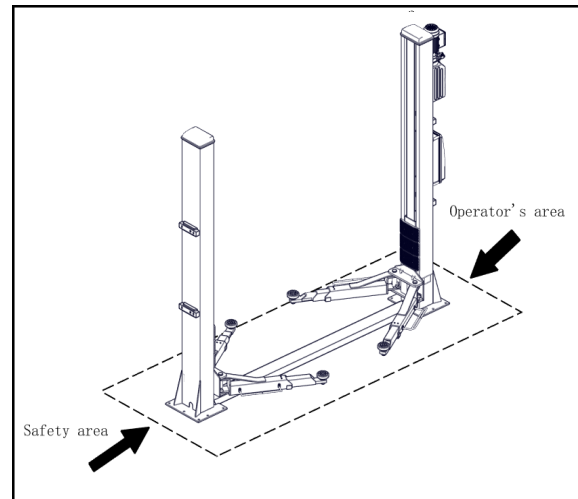

Fig. 8 Working Area

3.1 GENERAL PRECAUTIONS

The operator and the maintenance fitter are required to observe the prescriptions of accident prevention legislation in force in the country of installation of the lift.

Furthermore, the operator and the maintenance fitter must:

- ◆ Always work in the scheduled working area as shown in the manual;
- ◆ Never remove or deactivate the guards and mechanical, electrical, or other types of safety devices;
- ◆ Read the safety notices affixed to the machine and the safety information in this manual.

In the manual all safety notices are shown as follows:

DANGER: indicates imminent danger that can result in serious injury or death.

WARNING: indicates situations and/or types of maneuvers that are unsafe and can cause injuries of various degrees or death.

CAUTION: indicates situations and/or types of maneuvers that are unsafe and can cause minor injury to persons and/or damage the lift, the vehicle or other psaltery.

3.2 RISKS OF ELECTRIC SHOCK

Specific safety notice affixed to the lift in areas where the risk of electric shock is particularly high.

3.3 RISKS AND PROTECTION DEVICE

We shall now examine the risks to which the operator and the maintenance fitters may be exposed when the vehicle is immobilized in the raised position, together with the protection devices and adopted by the manufacture to reduce all such hazards to the minimum.

3.4 LONGITUDINAL AND LATERAL MOVEMENT

Longitudinal movement is considered the backward and forward shifting of the load.

Lateral movement implies the shifting to the left or right of the vehicle, especially during the lifting phase on the rack.

These movements can be avoided by positioning the vehicle correctly on the arm disk support plates, which must be previously adjusted to the same height (by loosening or tightening) as the vehicle.

Do not move the vehicle in relation to the arms or adjust arms and disk support plates until the arms have been totally lowered, i.e. the disk support plates must be free from all contact with the vehicle.

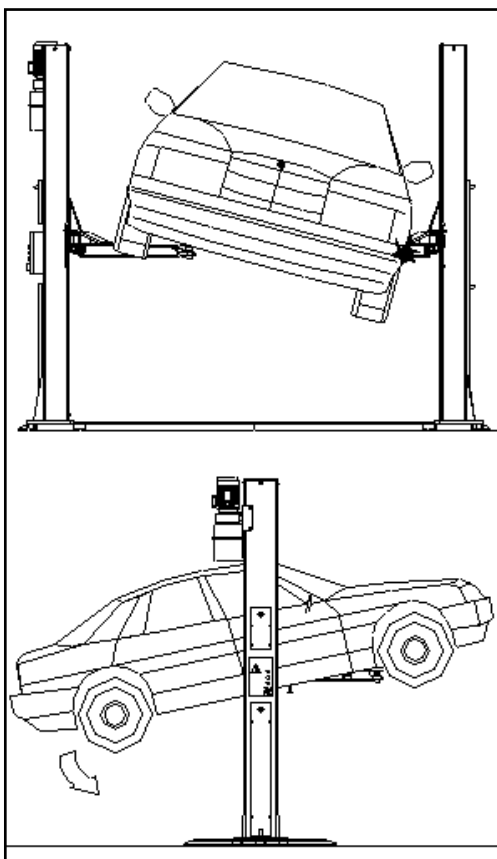

Fig. 9 Risk of Vehicle Fall

WARNING

DO NOT ATTEMPT TO MOVE THE VEHICLE WHEN IT IS RESTING ON THE DISK SUPPORT PLATES.

It is important to position the vehicle on the lift so that the weight is correctly distributed on the arms. (Fig. 10) For person and equipment safety, it is important that:

- ◆ People rest inside the safety area while the vehicle raising. (Fig. 8)
- ◆ The engine is off, the clutch engaged and the parking brake pulled.
- ◆ The vehicle is correctly positioned. (Fig. 10)
- ◆ Only authorized vehicle (Fig. 6 & Fig. 7) are raised without exceeding the rate capacity and overall dimensions.

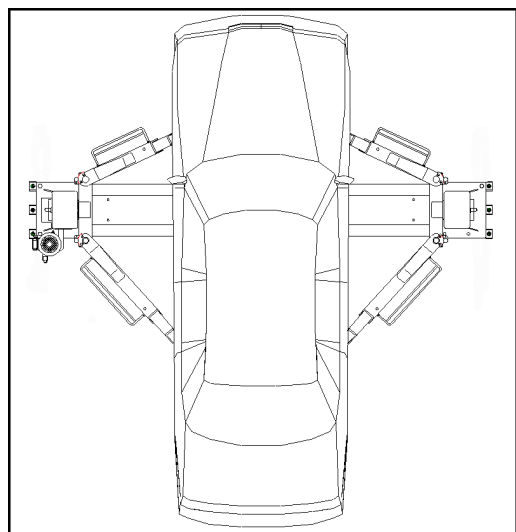

Fig. 10 Correctly Loaded Vehicle

3.5 RISKS WHILE THE VEHICLE IS BEING RAISED

The following safety devices have been installed to protect against overweight conditions and equipment failure:

- ◆ The thermal relay in the electric box will trip if the motor is overloaded.
- ◆ The maximum pressure valve (Fig. 11), located on the hydraulic oil power unit, will trip if the lift is overloaded.

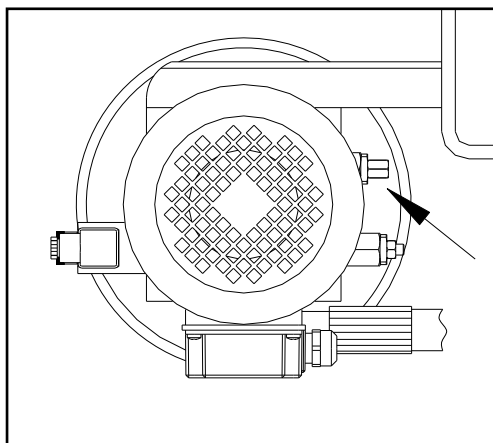

Fig. 11

- ◆ In case of a sudden, great leakage in the hydraulic circuit (a broken pipe), the blocking valves, at the bottom of each Cylinder, will trip.
- ◆ If the lift reaches to the maximum height, the up limit switch will stop the lifting. (Fig.13)

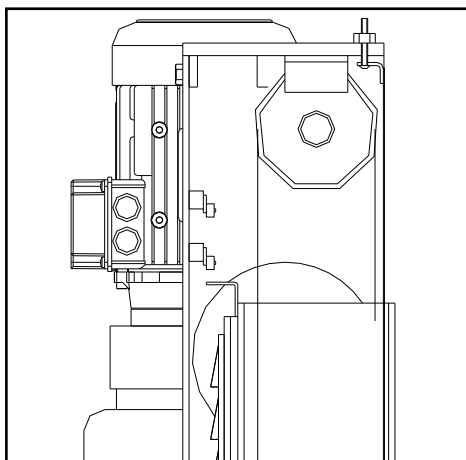

Fig. 13

- ◆ Keep both cables in balance during raising or lowering. (Fig. 14)

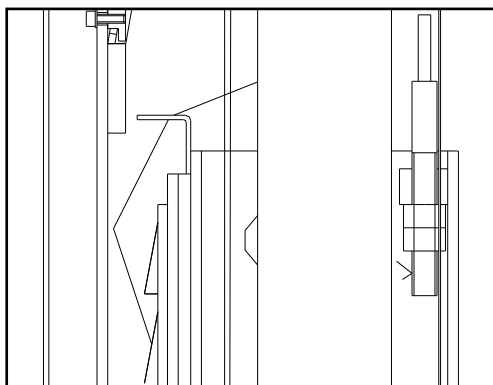

Fig. 14

- ◆ If the hydraulic cylinder breaks, the safety wedges will trip (Fig. 15), located inside the posts. The wedges are pushed by the spring and immediately stop the carriage preventing their descent.

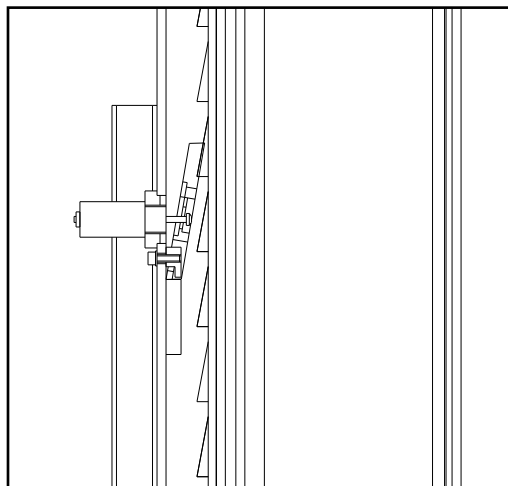

Fig. 15

- ◆ If the moving part exceed its travel distance, on the upper part of the command post there is two limit switches connected in series and are usually set working by the “actuator” (Fig. 13) on the command side carriage. If the first limit switch did not work, the second one would trip after 3sec of carriage run.
- ◆ In case of total breakdown of the limit switches, the carriage will stop a few millimeter higher. Because the hydraulic cylinders come to end stroke, will cause the maximum pressure valve (on hydraulic unit) to trip.

3.6 RISKS OF PERSONS

This paragraph illustrates risks to which the operator, maintenance worker, or any person near the operating area of the lift may be exposed in the case of impeccable use of equipment.

3.6.1 RISK OF CRUSHING (OPEARATOR)

Possible if the operator controlling the lift is not in the specified position at the command panel. When the platform and the vehicle are descending, the operator must never be partly or completely underneath the moving structure. During this phase, the operator must remain in the command zone. (Fig. 16)

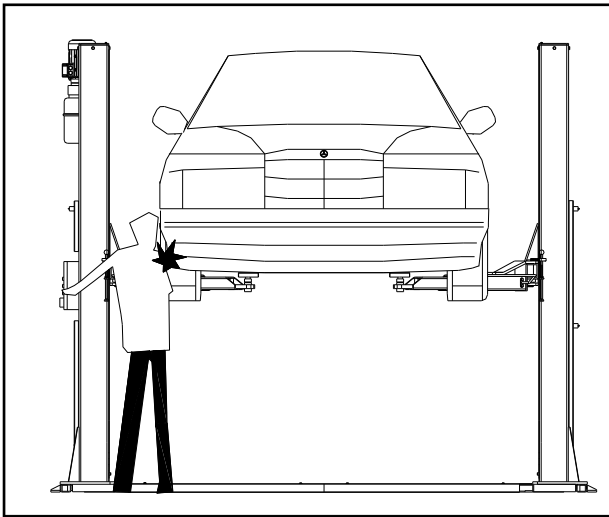

Fig. 16

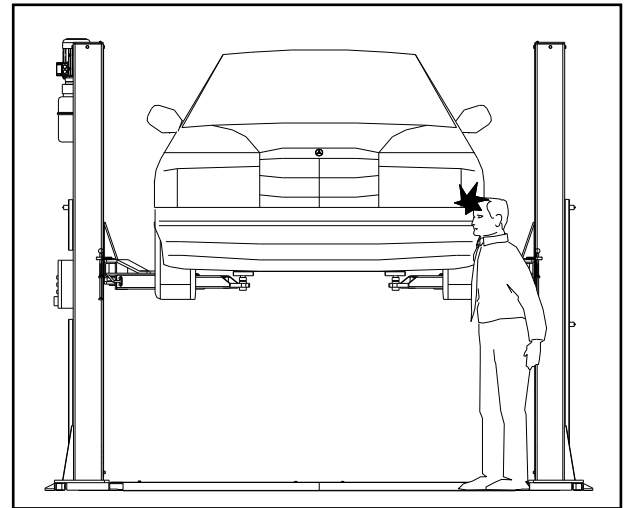

Fig. 18

3.6.2 RISK OF CRUSHING (PERSONNEL)

When the platform and the vehicle are descending, personnel are prohibited from entering the area beneath the moving parts of the lift. (Fig. 17) The lift operator must not start the maneuver until it has been clearly established that there are no persons in potentially dangerous positions.

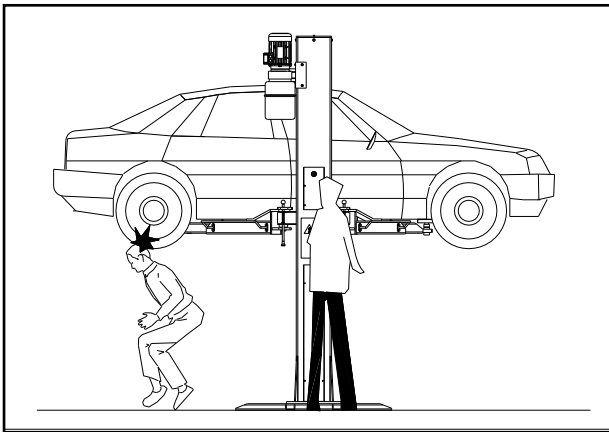

Fig. 17

3.6.4 RISK DUE TO VEHICLE MOVEMENT

Movement may be caused during operations, which involve force sufficient to move the vehicle. (Fig. 19) If the vehicle is of considerable dimensions or weight, movement may lead to overload or unbalancing. All measures must be taking to avoid such an occurrence.

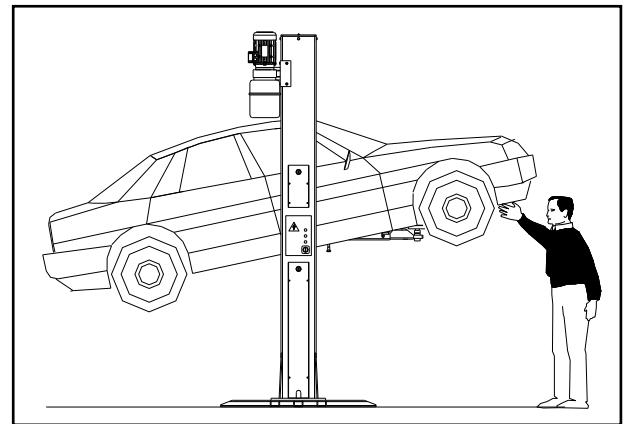

Fig. 19

3.6.3 RISK OF IMPACT

Caused by the parts of the lift or the vehicle that are positioned at head height. When, due to operational reasons, the lift is immobilized at relatively low elevations (less than 1.75m from the ground) personnel must be careful to avoid impact with parts of the machine not marked with special hazard coloring. (Fig. 18)

3.6.5 RISK OF VEHICLE FALLING FROM LIFT

This risk could be caused by the incorrect positioning on the arm disk support plates (Fig. 20) or in incorrect position of the arm disk support plates in relation to the lift.

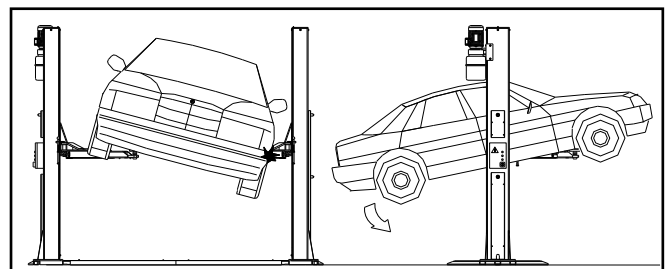

Fig. 20

NEVER BOARD THE VEHICLE AND/OR TURN THE ENGINE ON WHEN LIFT IS RAISED. (Fig. 21)

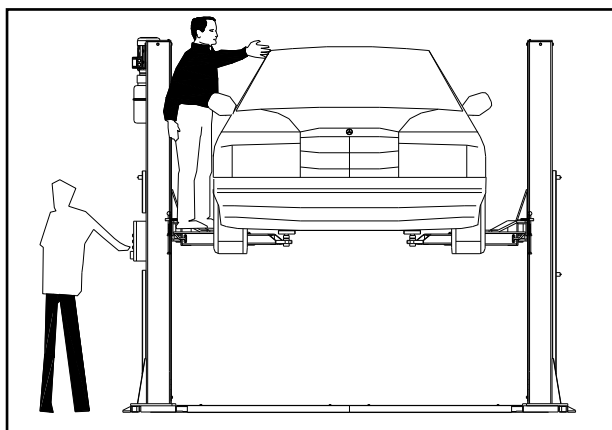

Fig. 21

NEVER LEAN OBJECTS AGAINST THE POSTS OR LEAVE THEM IN THE AREA WHERE MOVING PARTS ARE LOWERED.

This could hamper lowering or cause the vehicle to fall from the rack. (Fig. 22)

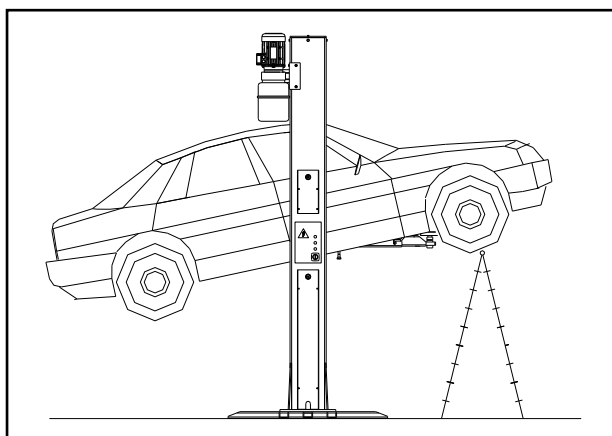

Fig. 22

3.6.6 SLIPPING

This risk may arise due to spillage of lubricants in the surrounding area. (Fig. 23)

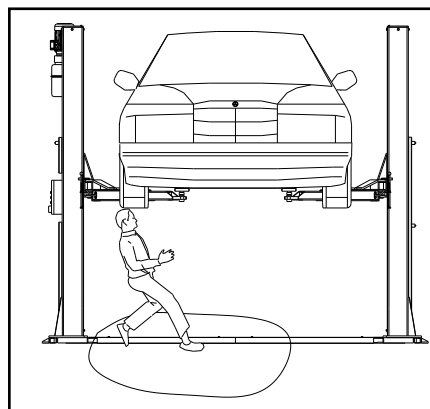

Fig. 23

ALWAYS KEEP THE AREA SURROUNDING AND THE LIFT CLEAN BY REMOVING ALL OIL SPILLS.

To avoid the risk of slipping, make use of the recommended personal protection (anti-slip footwear).

3.6.7 RISK OF ELECTRIC SHOCK

Risk of electric shock in areas of the lift housing electric wiring. Do not use jets of water, steam (high pressure wash units), and solvents or paint in the immediate vicinity of the lift, and take special care to keep such substances clear off the electrical command panel. (Fig. 24)

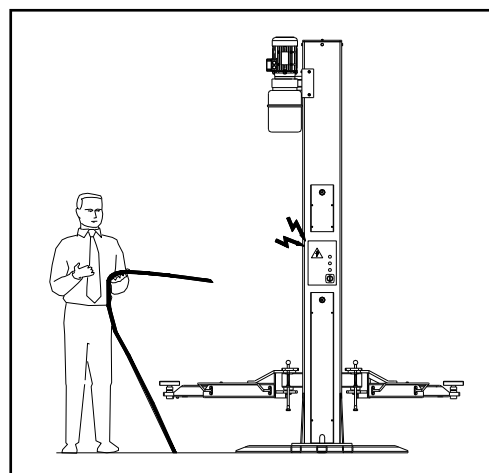

Fig. 24

3.6.8 RISK OF COMPONENT FAILURE DURING OPERATION

The manufacturer has used appropriate materials and construction techniques in relation to the specified use of the machine in order to manufacture a reliable and safe lift. Note, however, that the lift must be used in conformity with the manufacturers prescriptions and the frequency of inspections and maintenance work recommended in *Chapter 6 "MAINTENANCE"* must be observed.

3.6.9 RISK RELATED TO IMPROPER USE

Persons are not permitted to stand or sit on the platforms during the lift maneuver or when the vehicle is already lifted. (**Fig. 25**) All uses of the lift other than the uses for which it was designed are liable to give rise to serious accidents involving the persons working in the immediate vicinity of the unit. It is therefore essential to adhere scrupulously to all regulations regarding use, maintenance and safety contained in this manual.

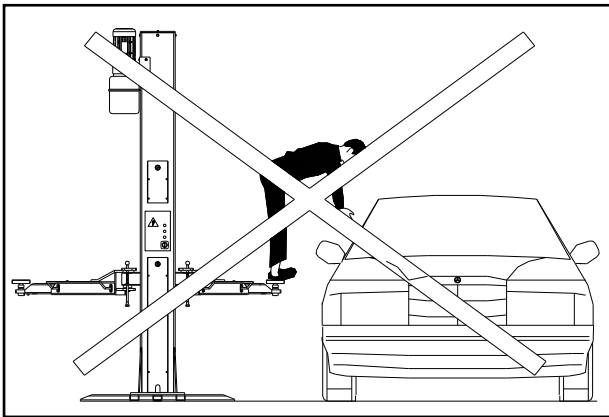

Fig. 25

3.7 SAFETY INSTRUCTINS FOR SERVICING

- ◆ Maintenance or repair work by authorized service personnel only.
- ◆ Turn off and padlock the main switch before doing any maintenance, or repair work.
- ◆ Work on pulse generators or proximity switches by authorized service personnel only.
- ◆ Work on the electrical equipment by certified electricians only.
- ◆ Do not replace or override the safety devices.
- ◆ Ensure that ecologically harmful substances are disposed of only in accordance with the appropriate regulations.

TECHNICAL STAFF WITH AUTHORISATION FROM THE MANUFACTURER OR LICENSED DEALER. IF THESE OPREATIONS ARE PERFORMED BY OTHER PERSONS, SERIOUS PERSONAL INJURY AND/OR IRREPERABL DAMAGE TO THE LIFT UNIT MAY RESULT.

4.1 INSTALLATION REQUISITE CHECKLIST

The lift is designed for installation in enclosed areas suitably protected from the weather. The place of installation must be well clear of areas destined to washing or painting, and away from solvent or paint storage areas or areas where there is a risk of potentially explosive atmosphere.

SUITABILITY OF THE DIMENSIONS OF THE PLACE OF INSTALLATION AND SAFTY CLEARANCE.

The lift must be installed in observance of the clearances between walls, pillars, other machines, etc. indicated in **Fig. 26** and in compliance with any legislative requirements in the county of installation.

Check in particular:

- ◆ **Minimum height:** 5000mm inclusive of height of vehicle, maximum height of arms, (i.e. 1900mm), and upper post height (i.e. 2828mm)
- ◆ **Min. distance from walls:** 600mm
- ◆ **Min. working area:** 700mm
- ◆ Area for command station
- ◆ Area for maintenance, access and emergency escape routes.
- ◆ Position in relation to other machines
- ◆ Proximity to power supply for trouble-free hook-up

Chapter 4 INSTALLATION

THE FOLLOWING OPERATIONS MUST BE PERFORMED EXCLUSIVELY BY SPECIALISED

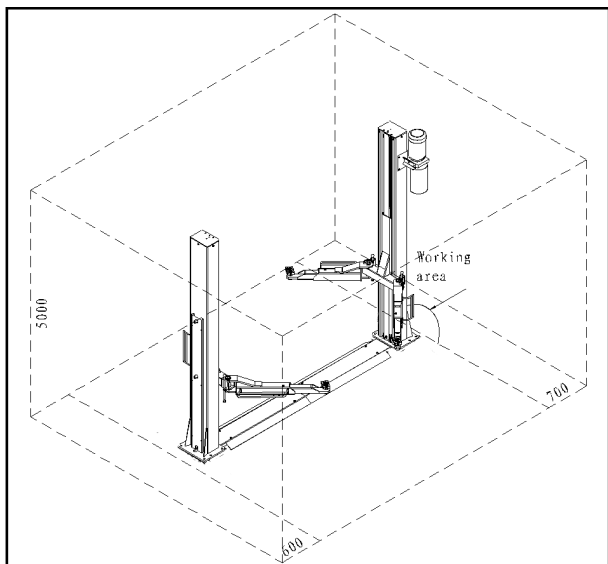

Fig. 26

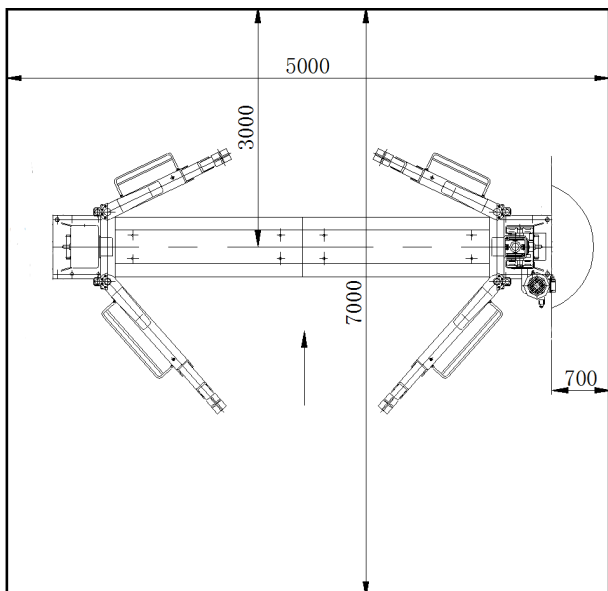

Fig. 27

4.2 LIGHTING

All parts of the machine must be uniformly lit with sufficient light to assure that the adjustment and maintenance operations specified in the manual can be performed, and without areas of shadow reflected light, glare and avoiding all situations that could give rise to eye fatigue.

The lighting must be installed in accordance with the laws in force in the place of installation (responsibility lies with the lighting equipment fitter).

4.3 FLOOR

The lift must be installed on a horizontal concrete bed with a minimum thickness of 200mm built and a resistance $\geq 30\text{N/mm}^2$.

The floor must also be flat and level (10mm of tolerance for leveling). Consult the manufacturer with regard to special applications.

4.4 ASSEMBLING

WARNING

DURING INSTALLATION ONLY AUTHORISED PERSONNEL IS ALLOWED.

To assemble the lift, the weight of the various parts is to be considered, in order to provide a lifting machine with the minimum capacity 500kg and max. lifting height of 2900mm.

Before starting to assemble the lift, check the crate contains all the needed material.

4.4.1 POST ASSEMBLING

- ◆ Install both boards on the bases, keep the main column upright, and put the stiffers which are no less than 100mm on the upside for the convenience of installing the safety device, cable, hose and wire.
- ◆ Install the safety devices including electromagnet, automatic locking board and hock board inside both columns. (Fig. 28) The first step should install the safety devices under both columns.

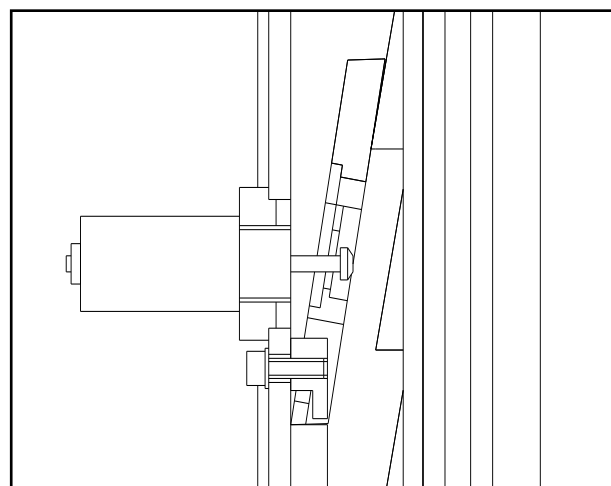

Fig. 28

- ◆ Install the balance cable according to Fig. 29. The cable also can be crossed from the hole on the board before the fixing of both columns.

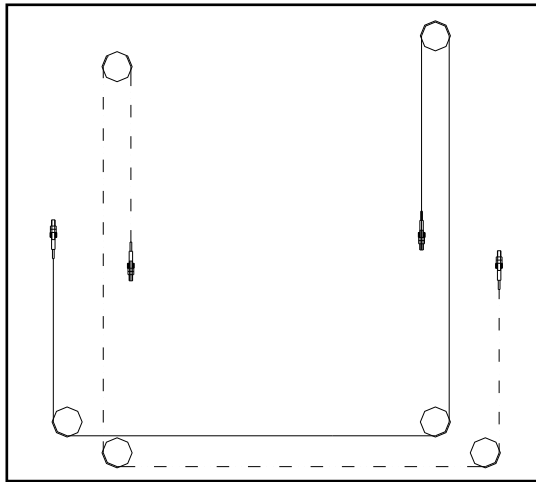

Fig. 29

- ◆ Connect the high-pressure hose. First connect the hose with tri-joint under the main column and the bend under the sub-column. Fix them after upright the columns.
- ◆ Cross the wires which are using to connect the electromagnet on the sub-column from the hole on both bases.
- ◆ Hold up both columns (keep the carriage lock and in the same level), and then fix the bolts on the base.
- ◆ Install the safety devices.
- ◆ Adjust both cables and keep the carriage in balance.
- ◆ Screw the joint of the high-pressure hose and fix it on the base.

4.4.2 HYDRAULIC PALNT

- ◆ Install the pump on the hock board according to Fig. 31 and fix it on the bottom of main column.

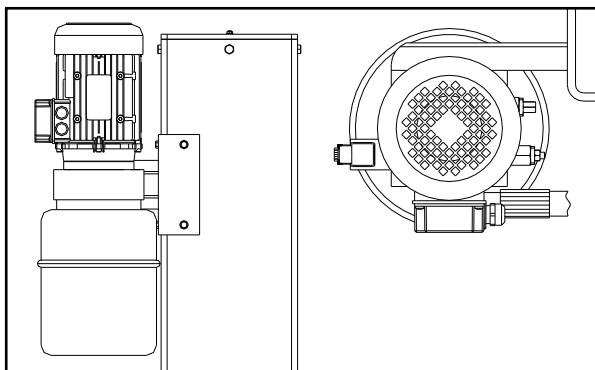

Fig. 31

- ◆ Connect the hydraulic unit to the circuit crossing with a flexible pipe. (Fig. 32)

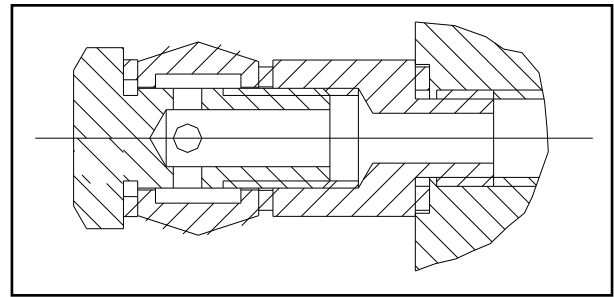

Fig. 32

- ◆ Tight all the fittings very well, even the one already mounted by the manufacturer.
- ◆ Fill the hydraulic unit tank with 8 liters of hydraulic oil ISO 32 as IP HYDRUS OIL 32, SHELL TELLUS OIL T32 or similar (See Chapter 2, TECHNICAL SPECIFICATIONS).
- ◆ Remove the oil filling cap and substitute it with the given drain cap.

4.4.3 ELECTRIC PLANT CONNECTION

WARNING

The operations listed below must be performed by skilled personnel.

4.4.3.1 Before connecting the electric system, make sure that:

- ◆ The power supply plant to the lift is equipped with the protection device required by current standards in the country where the machinery is installed.
- ◆ The power supply line has the following cross-section:

Lift voltage 400V, three-phase.....	Min. 2.5mm ²
Lift voltage 230V, three-phase.....	Min. 4mm ²
Lift voltage 230V, single-phase.....	Min. 6mm ²
- ◆ The voltage oscillations are within the tolerance range set forth by the specifications.

The manufacturer supplies the rack to operate at 400V with a three-phase configuration; if the line voltage is different, the motor and transformer connection must be changed. (Fig. 33) It is also necessary to replace the thermal relay

requesting that part from the manufacture and/or service center.

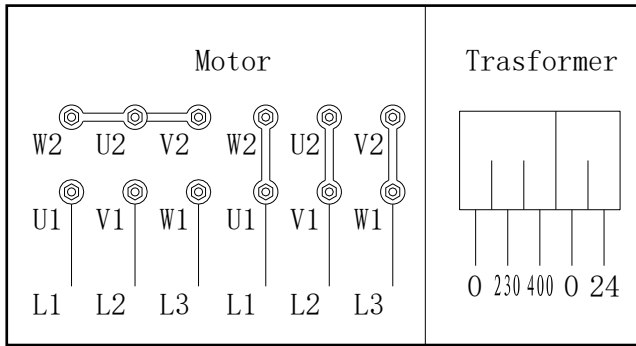

Fig. 33

4.4.3.2 Connect the power and control system to the terminal strip on the control box, inserting the cable into the rack passing through the prepared hole and following the wiring diagram on **Page 23**.

- ◆ Install the electric box on the main column.
- ◆ Connect the limit switches.
- ◆ Complete the solenoid valve (on the hydraulic unit) connection.
- ◆ Connect the electromagnets.
- ◆ Connect the electric motor.
- ◆ Complete the voltage and command connections to the control panel clamp box.

4.4.3.3 The wires should be fixed by nylon pitch.

4.4.3.4 Close the cover of the electric box, turn the main switch to position 1, press the up push button (**Fig. 34**), the motor rotation direction should be the one shown by the arrow on the pump.

BEWARE: The pump rotating for a long time in the wrong sense may cause itself serious damages.

4.4.3.5 Make sure that the post end limit switches work properly by pressing them manually.

4.4.4 ARM ASSEMBLING

- ◆ Press the up push button, raise the carriages to a height of about 70cm off the ground, then press the lock push button, **SET THE MAIN SWITCH (IG) TO POSITION 0 AND CUT OFF THE POWER SUPPLY TO THE LIFT.**

- ◆ Grease the holes $\phi 40$ on the arms ends.
- ◆ Mount the arms into the carriage supports and insert the dowel pins into the support holes as shown in **Fig. 35**. Notice the entry of both arms is the same with the entry of the vehicle.

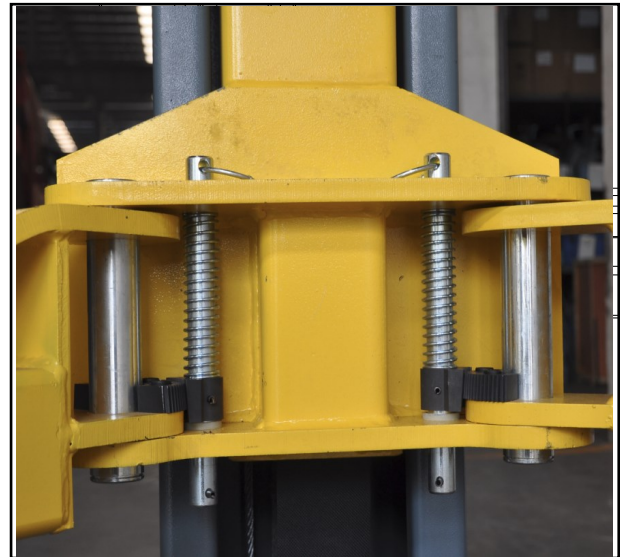

Fig. 35

- ◆ Block the spring ring at the end of the pin.

WARNING

End-user should confirm that the over load device must be connected before the electrical power connected to lift.

4.4.5 INSTALL THE COVER PLATE

Install the two cover plates at the chassis by 8 pieces M8×16 bolts.

4.4.6 INSTALL SPRING SCREW

- ◆ Make 14 drills on the basement with a helical concrete bit with a diameter of 18mm to a depth to 130mm. Use the basis pad as a drilling template.
- ◆ Install the screw according to **Fig. 28**.

4.5 TESTING AND CHECKS TO PERFORM BEFORE START-UP

4.5.1 MECHANIAL TESTS

- ◆ Attachment and tightness of bolts, fittings and connections
- ◆ Free sliding of moving parts

- ◆ Clean state of various parts of the machine
- ◆ Position of the protection device
- ◆ Arms blocking device

4.5.2 ELECTRIC TESTS

- ◆ Connection comply with diagrams
- ◆ Machine earth connections

4.5.3 OPERATING OF THE FOLLOWING DEVICES

- ◆ Rise limit switch
- ◆ Security device electromagnets
- ◆ Hydraulic oil plant solenoid-valve

4.5.4 HYDRAULIC OIL TEST

- ◆ Sufficient oil in the tank
- ◆ No leaks
- ◆ Cylinder operation

NOTE: If oil is not present, fill the reservoir of the power unit with the necessary amount of oil .See the procedure in Chapter 6: MAINTENANCE

4.5.5 ROTATION DIRECTION TEST

The motor should turn in the direction of the arrow located on the power unit pump; check using brief start-ups (each start-up must last a maximum of two seconds). If problems arise in the hydraulic oil plant, see the “Trouble-shooting” table in Chapter 7.

4.6 SET UP

WARNING

THESE OPERATIONS MUST ALWAYS BE PERFORMED BY TECHNICIANS OF THE AUTORIZ SERVICE CENTRE INDICATED IN THE FRONT OF THIS MANUAL.

4.6.1 NO-LOAD TESTS

In this phase check the following:

- ◆ That the up, down and lock push buttons operate correctly;

- ◆ That the rack reaches the maximum height;
- ◆ That there are no abnormal vibrations in the posts and in the arms;
- ◆ That the safety wedges enter the iron pads under the carriage;
- ◆ That the rise limit switches trip;
- ◆ That the electromagnet trips;
- ◆ After having done all as previously recommended, the height difference between the arms of the two carriages, is less than 1cm. On the contrary, adjust their level by working on the counter nuts on the synchronous steel cables.

To perform the tests listed about, complete two or three complete up and down cycles. This is also to be done in order to make the air in the hydraulic circuit going out.

4.6.2 LOAD TESTS

Repeat the previous tests with the vehicle on the rack.

After the load tests, visually inspect the machinery and check again that all bolts are tightened.

Chapter 5 OPERATIONS AND USE

The lift Commands (control devices) is shown as *Fig. 34*.

5.1 CONMANDS

5.1.1 MAIN SWITCH (IG)

POSITION 0:

The lift is not energized. It is possible to access the interior of the box and lock the switch to prevent use of the lift.

POSITION 1:

This energizes the lift and lock the door of the box to prevent it from being opened accidentally.

5.1.2 UP PUSH BUTTON

“Man present” type, it operates under 24V and if pressed, activates the electric motor and mechanisms that lift the carriage.

5.1.3 DOWN PUSH BUTTON

“Man present” type, it operates under 24V and if pressed, activates the safety wedge electromagnets and the power unit exhaust valve.

5.1.4 LOCK PUSH BUTTON

“Man present” type, it operates under 24V and if pressed, activates the oil discharge electro-valve in the hydraulic power unit and it deactivates the electromagnets, placing the load in the parking position on the safety wedges.

5.2 OPERATING SEQUENCE

Position the lift arms in the hold points prescribed for the vehicle, adjusting the disks to the same height.

Each time the carriages are brought down to the ground, check the position of the disks under the chassis of the vehicle before raising the carriages again.

5.2.1 LIFTING

Turn the main switch (IG) to the position 1 and press the up push button until reaching the required height. As the carriages are raised the safety wedges are inserted automatically into each the iron pad under the carriage. Regarding lift limits and safety devices, *see pages 6, 7 “RISKS WHILE THE VEHICLE IS BEING RAISED”*.

5.2.2 PARKING

Once the required height has been reached, press the lock push button. The movement is stopped automatically when the safety wedge rests on the level of the first slot that they come in contact with while the carriages are coming down.

5.2.3 LOWERING

Before lowering the carriages, the safety wedges must be disconnected. Press the down push button that the carriage will be lift about 3-cm, then automatically releases the safety wedges and activates the down electro-valve. Lowering speed is regulated by the “flow regulating valve” in the pump. Lowering stops when the hydraulic cylinders are completely unloaded. When the carriages are totally lowered, the automatic arm-blocking device opens and lets the carriages rotate.

Chapter 6 MAINTENANCE

6.1 PRECAUTIONS

WARNING

Maintenance must be carried out ONLY BY SKILLED PERSONNEL WHO ARE VERY FAMILIAR WITH THE LIFT.

When performing maintenance on the lift, follow all the necessary precautions to ***PREVENT THE LIFT FROM BEING STARTED ACCIDENTALLY:***

- ◆ The main switch on the control box must be locked in POSITION 0 by using a LOCK.
- ◆ THE KEY for the lock must be kept by the MAINTENANCE FITTER.
- ◆ While maintenance is being performed on the machine, always keep in mind all the main possible risks and the safety instructions indicated in ***Chapter 3 "SAFETY RISK OF ELECTRIC SHOCK"*** at the machine power supply terminal strip.

IT IS PROHIBITED TO PERRORM MAINTENANCE ON AND LUBRICATES MOVING PARTS.

IMPORTANT

To ensure cable maintenance:

- ◆ Only use original spare parts and tools that are suitable for the job and in good condition;
- ◆ Follow the maintenance schedule indicated in the manual: these frequencies are indicative and must always be considered as general rules to be respected.
- ◆ Good preventive maintenance requires constant attention and continuous supervision on the machine. Quickly find the cause of any abnormalities such as excessive noise, overheating, leaking fluids, etc.

Special attention is required for:

- ◆ The condition of lifting parts (cylinder, power unit);
- ◆ Safety devices (micro switches, electromagnets and safety wedges)

To perform maintenance correctly, refer to the following documents supplied by the rack manufacturer:

- ◆ Complete functional diagram of the electric equipment and auxiliary equipment indicating the power supply connections;
- ◆ Hydraulic diagram with lists of parts and max. pressure values;
- ◆ Exploded drawings with the data needed to order spare parts;
- ◆ List of the possible causes of malfunctions and recommended solutions (***Chapter 7*** of the manual).

6.2 PERIODIC MAINTENANCE

6.2.1 OPERATION FREQUENCY

To keep the lift working at full efficiency, follow the indicated maintenance schedule. The manufacturer will not be responsible and will not honor the warranty as a result of non-compliance with the instructions indicated above.

NOTE

The frequency indicated refers to normal operating conditions. Different frequencies will apply to particularly server conditions.

ALL MAINTENANCE OPERATIONS MUST BE PERFORMED WITH THE LIFT STOPPED AND THE MAIN SWITCH KEY LOCKED.

When after the machine has been installed, check:

- ◆ The tightness of the posts bases connection anchor bolts;
- ◆ The tightness of the beam to posts attachment screws;
- ◆ That the opposite carriages arms are at the same level;
- ◆ The power unit oil level. Add oil up to the right level, if necessary.

6.2.2 EVERY MONTH

HYDAULIC POWER UNIT

- ◆ Check the oil level, using the special dipstick, which is attached to the filler cap. If necessary, add oil through the cap to reach the required level. For the

type of oil, *see Page 3 "TECHNICAL SPECIFICATIONS"*.

- ◆ After the first 40 hours of operation, check if the conveyors or filter is clogged and the oil contamination level. (Clean the filter and replace the oil if there is a high contamination level).

HYDAULIC CIRCUIT

Check that there are no oil leaks in the circuit between the power unit and cylinder and in the cylinder itself. In this case, check the condition of the gaskets and replace them, if necessary.

6.2.3 EVERY 3-MONTH

HYDAULIC PUMP

Under normal operating conditions, check that there is no changes in the noise in the power unit pump and check that the relative bolts are properly tightened.

SYNCHRONOUS SYSTEMS

- ◆ Check the operating condition and efficiency of the safety devices (*as described at pages 6, 7*) and the wear on the safety wedges and relative hinge pins. Oil the pins on the safety wedges. In case of excessive wear, replace the safety wedges and/or pins.
- ◆ Use a torque wrench to check that the post bases anchor bolts screws are properly tightened to the ground as well as the connection bolts.
- ◆ Clean and lubricate the carriage side runners and guides.
- ◆ Check that all screws are tightened
- ◆ Check that the arm locking system works properly.
- ◆ Grease all the moving parts.

6.2.4 EVERY 6-MONTH

HYDRAULIC

Check the contamination or aging level of the oil. Contaminated oil is the main cause of malfunctions of the valves and leads to a brief service life of the gear pumps.

SYNCHRONOUS CABLE

Check the pulleys and pulley races conditions. Control the cable wear by checking diameter, possible broken wires,

other damages or relevant changes. With a paintbrush grease the cable in order to avoid corrosion or breakage due to oxidation.

6.2.5 EVERY 12-MONTH

General check: visual inspection of all structural parts and mechanisms to guarantee that there are no problems or anomalies.

Electric plant: skilled electricians (contact the service center) should test the electric plant, including the motor of the power unit, cables, and limit switch and control box.

HYDRULIC PLANT OIL

Replace the oil, following the instructions listed below:

- ◆ Lower the lift to the minimum height (on the ground)
- ◆ Make sure that the hydraulic cylinder is at the end of its travel
- ◆ Disconnect the power supply to the lift rack.
- ◆ Drain the oil from the hydraulic circuit, unscrewing the plug located at the bottom of the power unit reservoir.
- ◆ Close the drain plug
- ◆ Fill the power unit with oil through the plug located at the top of the power unit reservoir.

The oil must be filtered:

- ◆ Oil characteristics and types are reported in the technical specifications (*Chapter 2, page 3*)
- ◆ Close the filler plug
- ◆ Energize the lift rack
- ◆ Go through two or three up-down cycles (for a height about 20-30 centimeters) to insert oil into the circuit.

When changing the oil: use only recommend oil or the equivalent; do not use deteriorated oil that has been in the warehouse for an extended period of time. Oil should be disposed as indicated in appendix "A", page 37.

AFTER EACH MAINTENANCE OPERATION, THE MACHINE MUST RETURN TO ITS INITIAL CONDITIONS, INCLUDING THE DISASSEMBLED PROTECTION AND SAFETY DEVICE.

To ensure good maintenance, it is important:

- ◆ To use only tools that are suitable for the job and original spare parts
- ◆ Follow the minimum maintenance schedule as indicated
- ◆ Immediately find the cause of any abnormalities (excessive noise, overheating, leaking fluids, etc)
- ◆ Pay special attention to lifting parts (cylinders) and safety devices
- ◆ Use all the documentation supplied by the manufacturer (wiring diagrams, etc)

6.3 PERIODIC LUBRIFICATION CHART

Lubricate the rack as indicated in Fig.40. Grease must be taken from perfectly closed tins and/or well preserved. Old or damaged grease may damage the lubricated part.

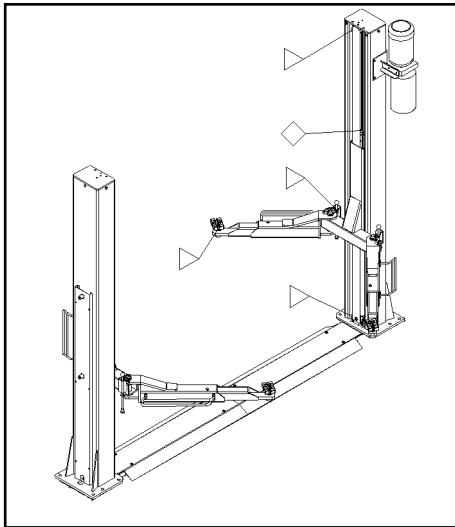

△ Lubricate every three months

□ Lubricate every six months

Fig. 36

Chapter 7 TROUBLESHOOTING

7.1 TROUBLESHOOTING GUIDE

Troubleshooting and possible repairs require absolute compliance with ALL THE SAFETY PRECAUTIONS indicated in *Chapter 6 “MAINTENANCE”* and *Chapter 3 “SAFETY”*.

7.2 POSSIBLE PROBLEMS AND SOLUTIONS

Problem	Possible Cause	Solution
The lift does not rise when the pushbutton is pressed (motor does not run)	Burnt fuse Line current does not arrive Malfunction in the electric plant: -Broken limit switch -burnt motor	Replace fuse Connect again Call Service Center
The lift does not rise when the pushbutton is pressed (motor runs)	Not enough oil Drain solenoid valve opened Max pressure valve working Leaks in the hydraulic circuit	Top up oil level Check electric connections or change it Take load down Repair the hydraulic circuit
Lift continues to rise after having released the up pushbutton	Faulty pushbutton	Unplug the lift and call Service Center
Lift does not descend	Foreign object Solenoid valve blocked Malfunction in the electric plant Carriages still lean on security devices Block valves have tripped	Remove object Change it (call Service Center) Call Service Center Make the correct descent sequence Repair the hydraulic circuit damage
The lift does not rise to the maximum height	Oil is not enough	Add oil into the power unit oil tank
After having released the up pushbutton, the lift stops and lowers slowly	Drain valve does not close because it is dirty Defective drain valve	At the same time set the rise and descent movements, to clean the valve Change (call Service Center)
The power unit motor overheats	Motor malfunction Wrong voltage	Call Service Center Check voltage
Power unit pump is noisy	Dirty oil Wrong assembling	Change oil Call Service Center
Oil leakage from cylinder	Damaged gaskets Dirt in the plant	Change the damaged gaskets Clean all parts Check the valves are not damaged

APPENDIX A SPECIAL NOTES

A.1 DISPOSAL OF USED OIL

Used oil, which is removed from the power unit and the plant during an oil change, must be treated as a polluting product, in accordance with the legal prescriptions of the country in which the lift is installed.

A.2 MACHINE DEMOLITION

DURING MACHINE DEMOLITION, COMPLY WITH ALL THE SAFETY PRECAUTIONS DESCRIBED IN CHAPTER 3, WHICH ARE ALSO VALID FOR ASSEMBLING.

The machine must be demolished by authorized technicians, just like for assembling. The metallic parts can be scrapped as iron. In any case, all the materials deriving from the demolition must be disposed of in accordance with the current standards of the country in which the rack is installed. Finally, it should be recalled that for tax purposes, demolition must be documented; submitting claims and documents according to the current laws in the country in which the rack is installed at the time the machine is demolished.

APPENDIX B

HYDRAULIC OIL HOSE CONNECTION DIAGRAM

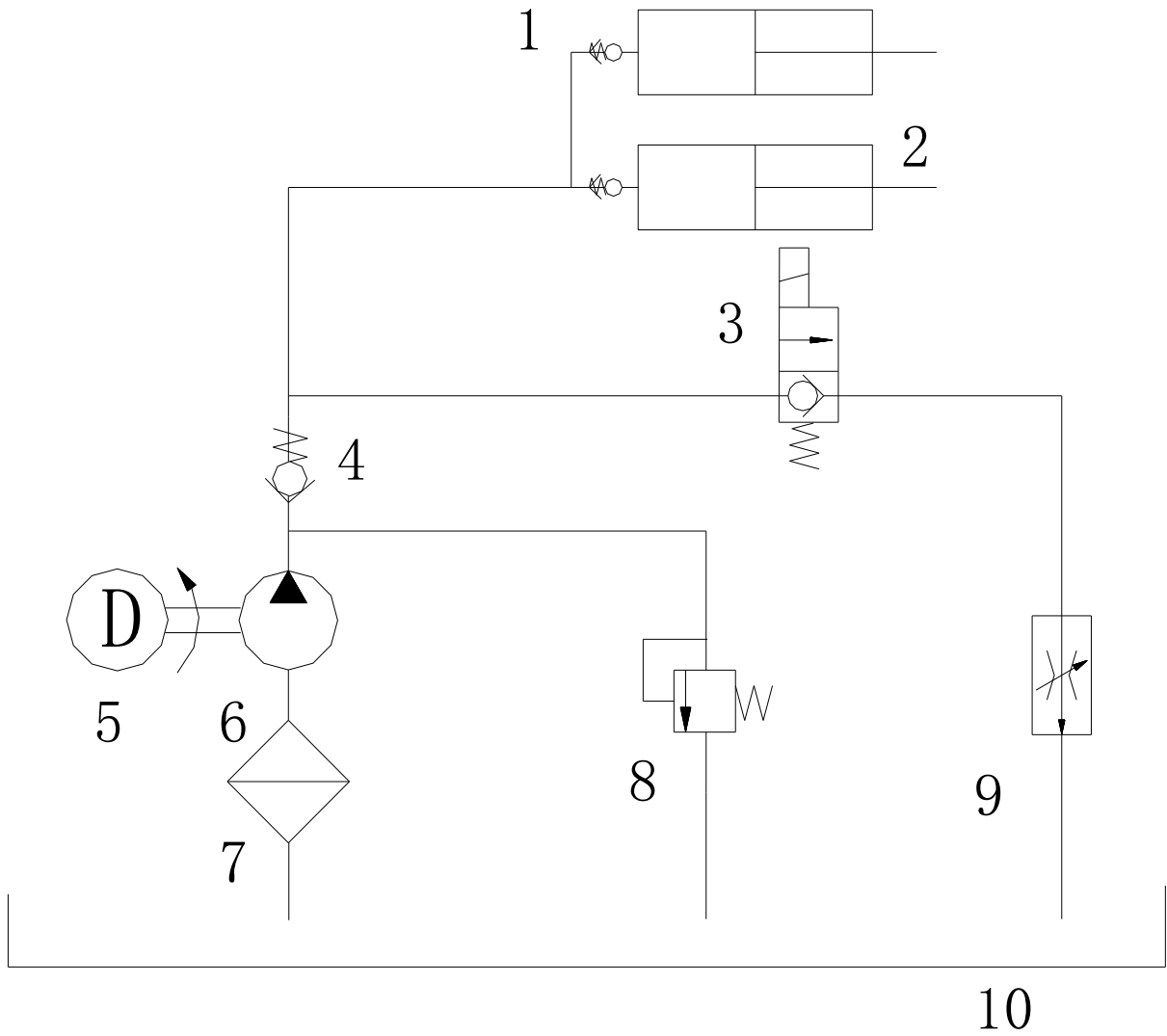

S/N	DESCRIPTION
1	Lock valve
2	Operating Cylinder with simple effect
3	Solenoid directional valve
4	Check valve
5	Motor
6	Pump
7	Filter
8	Pressure relief valve
9	Flow control valve
10	Tank

WARRANTY

The structural components on your new automotive lift are warranted for three years on equipment. Operating components are warranted one year to the original purchaser, to be free of defects in material and workmanship.

The manufacturer shall repair or replace at their option for this period those parts returned to the factory freight prepaid which prove after inspection to be defective.

This warranty only applies to the original purchaser of the equipment. This warranty does not extend to defects caused by ordinary wear, abuse, misuse, shipping damage, or damage as the result of improper maintenance.

This warranty is exclusive and in lieu of all other warranties expressed or implied.

In no event shall the manufacturer be liable for special, consequential or incidental damages for the breach or delay in performance of the warranty.

The manufacturer reserves the right to make design changes or add improvements to its product line without incurring any obligation to make such changes on product sold previously.